

ETAP TIP – No. 011

**Adding LV MCCB to the Library
(With Thermal-Magnetic Trip Unit)**

Applicable ETAP Versions: 5.5.0, 5.5.5, 5.5.6

(For lower versions, some of the descriptions and procedures below may differ in some ways)

Given:

Table 1: MCCB Data

Manufacturer		Fuji Electric	
Catalog No.		USEH605a	
Frame (A)		225	
Type		SA203BAUL	
Rated Insulation Voltage	AC	690	
Pole		3	
Rated Current (A)		125, 150, 175, 200, 225	
Rated Interrupting Capacity sym (kA)	IEC947-2	690V	Not available
	[Icu/Ics]	600V	15/8
		500V	18/9
		440V	25/13
		400V	30/15
		230V	50/25
Tripping Device		Fixed Thermal-magnetic (See Fig. 1a)	

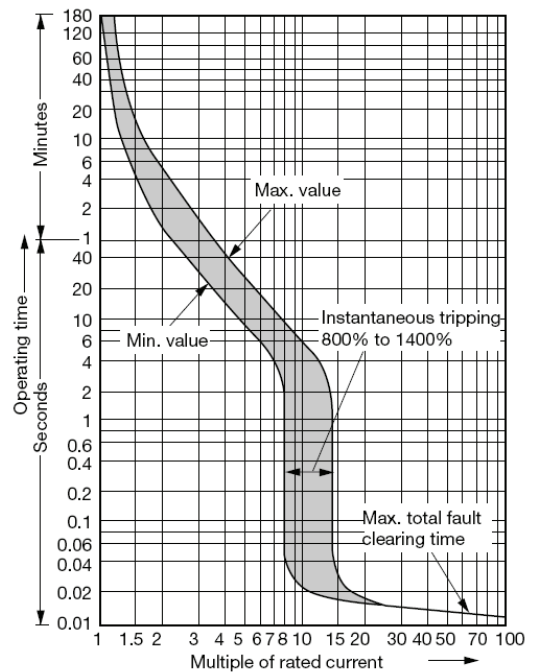

(a)

Procedure:

- A. Registering LV CB in the Library. There are 3 phases involved as follows:
 - I. Phase 1: Registering the breaker (model & ratings).
 - II. Phase 2: Registering the trip unit (characteristic curve).
 - III. Phase 3: Associating the breaker to the trip unit(s).
- B. Plotting the Characteristic Curve on TCC for Verification.

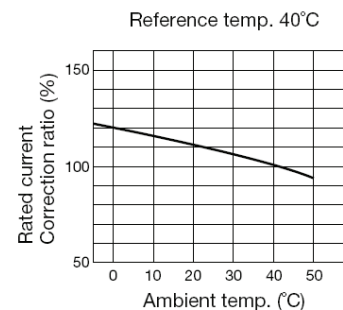

(b)

Fig. 1

A. Registering LV CB in the Library

I. Phase 1: Registering the breaker (data and ratings)

1. In this exercise, the data in Table 1 extracted from Fuji Electric catalog # “USEH605a” will be used.
2. Run ETAP 5.5.X program.
3. Open “Example-ANSI.oti” sample project.
Note: You may open any ETAP project.
4. Select the library file (where the new data is intended to be added) by doing the following:
 - a. From the main menu, select “Library→Open...” (see Fig. 2).
 - b. The “Warning” dialog box will be displayed. Click the “Yes” button. See Fig. 3.
 - c. Browse the “etaplib55X.lib” library file located at “Y:\ETAP 55X\Lib” folder. See Fig. 4.

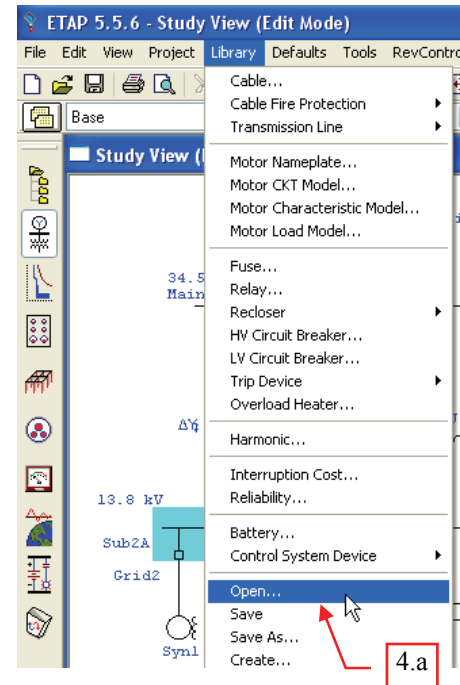

Fig. 2

Notes:

- i. “Y:\ETAP 55X” is the drive and folder where ETAP program was installed and “X” refers to the point release version of ETAP. If ETAP was installed on the default location, the drive and folder is “C:\ETAP 55X”.
- ii. The new data will be added to “etaplib55X.lib” library file.
- iii. You may create a copy of the “etaplib55X.lib” file using the “Windows Explorer” program and work on the copied file to preserve the default library file.
- iv. You may also create a new library file instead. To do so, from the main menu, select “Library→Create”. Browse to the folder where you want the library file to be located and enter the desired filename. Then, you may merge this library later with the other libraries.

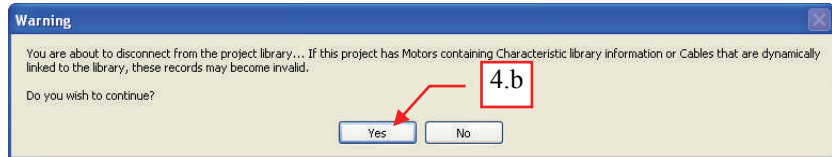

Fig. 3

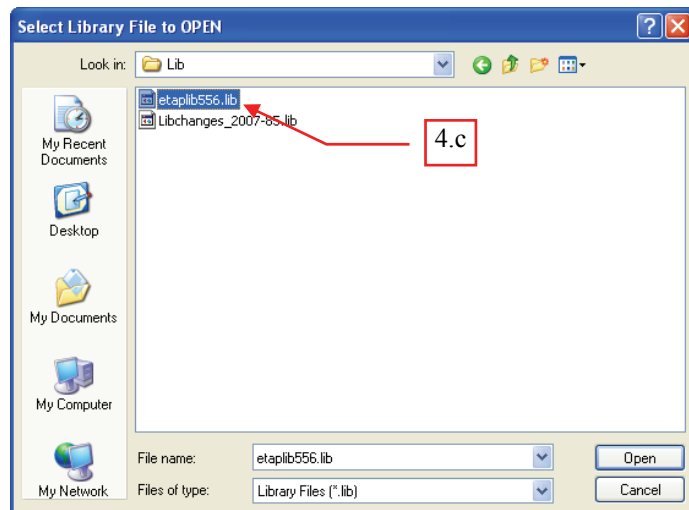

Fig. 4

5. To confirm that the library file you are working on is the “etaplib55X.lib”, do the following:

- Click the “Project View” button from the “Systems” toolbar. See Fig. 5a
- On the “Project View” window, scroll down and notice the “Libraries” folder is appended with the path and filename of the active library i.e. “Libraries- C:\ETAP 556\Lib\etaplib556.lib”. See Fig. 5b.

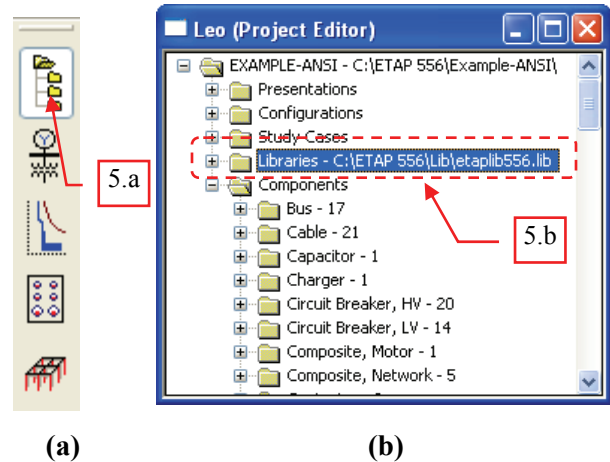

Fig. 5

6. Add the new LV MCCB device. From main menu, select “Library→LV Circuit Breaker...”

The “[X] LV Breaker Library – [Y]” dialog box will be displayed.

Notes:

[X]- is replaced by the standard (i.e. ANSI or IEC) currently active on the dialog box.

[Y]- is replaced by the circuit breaker type (i.e. Molded Case, Power CB, or Insulated Case) currently active on the dialog box.

7. Guided by the information in Table 1, page 1; In the “[X] LV Breaker Library – [Y]” dialog box, do the following (see Fig. 6):

- In the “Type” pull down box, select “Molded Case”
- In the “Standard” frame, select “IEC” radio button.
- Between the AC and DC radio buttons, select “AC”
- In the “Manufacturer” frame, click the “Add” button.

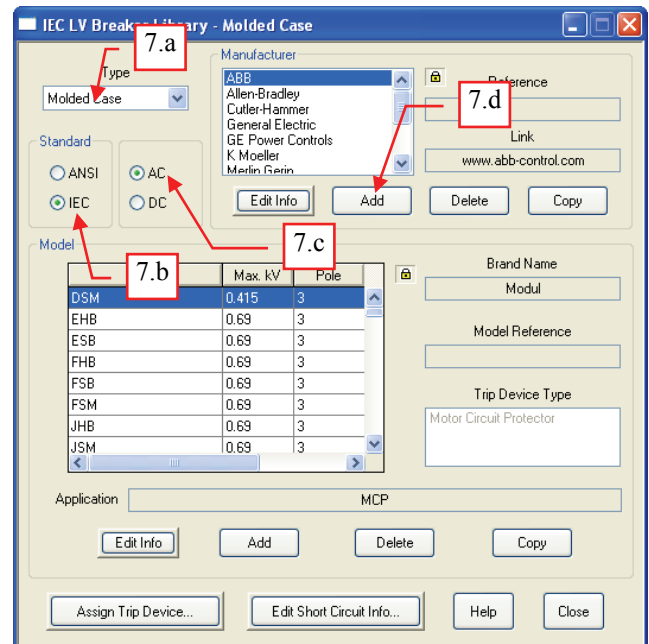

Fig. 6

The “LVCB Molded Case Library: Add” dialog box will be displayed.

Note: click the “Add” button only if the manufacturer is not yet available on the list box. Otherwise, just select the manufacturer.

8. Enter the following in the “LVCB Molded Case Library: Add” dialog box and click “OK”. See Fig. 7.

Manufacturer : Fuji Electric
Reference : “leave blank” (no info.)
Link : “leave blank” (no info.)

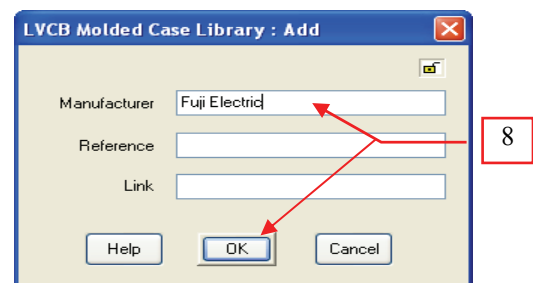

Fig. 7

9. With the “Fuji Electric” selected in the “Manufacturer” frame, click the “Add” button in the “Model” frame. See Fig. 8.

The “LVCB Molded Case Library: Add” dialog box will be displayed

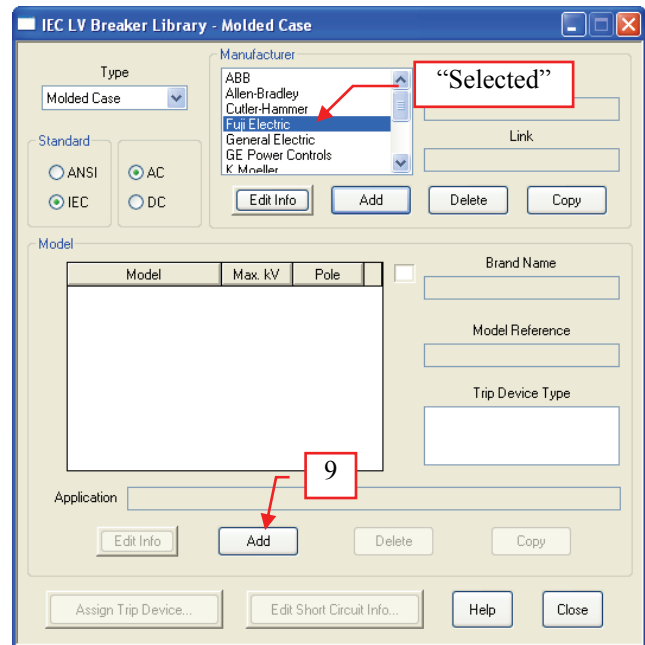

Fig. 8

10. Again, guided by the information in Table 1, page 1, in the “LVCB Molded Case Library: Add” dialog box, do the following (see Fig. 9):

- a. In the “Model” pull down box, type “SA203BAUL”
- b. In the “Pole” pull down box, select “3”
- c. In the “Max kV” pull down box, type “0.69”
- d. Check “Thermal-Magnetic” in the “Trip Device” frame
- e. In the “Model Info” frame, enter the following (for the fields not mentioned below, leave them blank since there is no available information)

Catalog # : USEH605a
 Frame Type : SA
 Frame Size : 225
 Certification : IEC 60947-2

- f. Click the “OK” button.

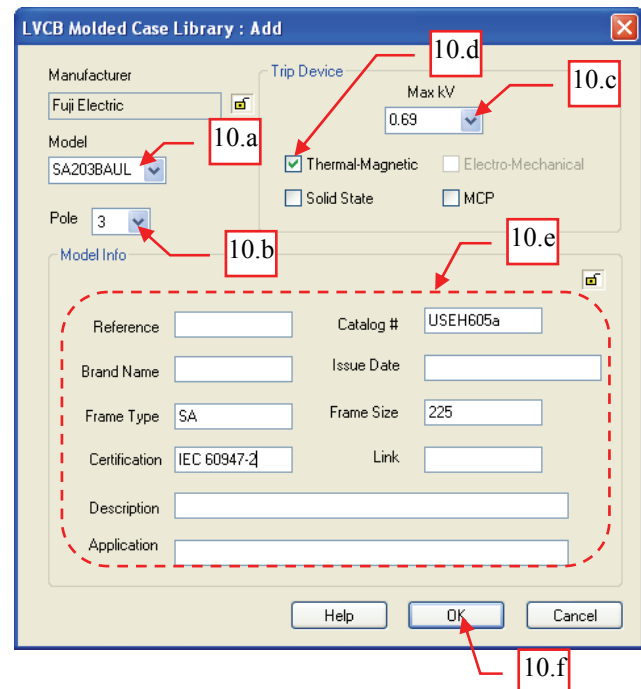

Fig. 9

ETAP TECHNICAL INFORMATION POINTERS

11. With the “SA203BAUL” selected in the “Model” frame, click the “Edit Short Circuit Info...” button. See Fig. 10.

The “LV Breaker Library” dialog box will be displayed.

12. Again, guided by the information in Table 1 on page 1, in the “LV Breaker Library” dialog box, do the following (see Fig. 11):

- a. Click “Add” button
- b. Enter the following data in the respective cells:

kV	:	0.6
Icu	:	15
Ics	:	8
Icm	:	30*
Icw	:	0 (no info.)
Tkr	:	0 (no info.)
Tripping time	:	0 (no info.)
Notes	:	Pf = 0.3 (in relation to value of Icm derived from Table II)

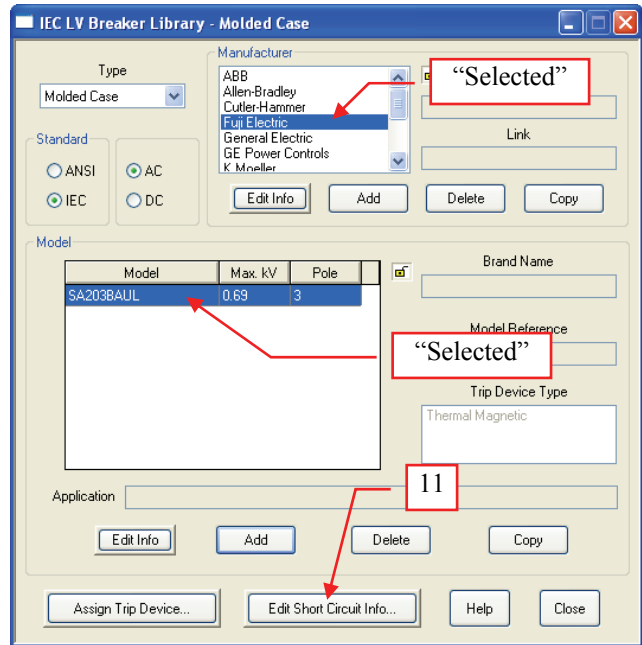

Fig. 10

* This value is not specified in the catalog. However, since the breaker is IEC 947-2 certified, the standard relationship between the short-circuit breaking and making capacity, and related power factor given in Table II of the said standard may be used to determine the Icm.

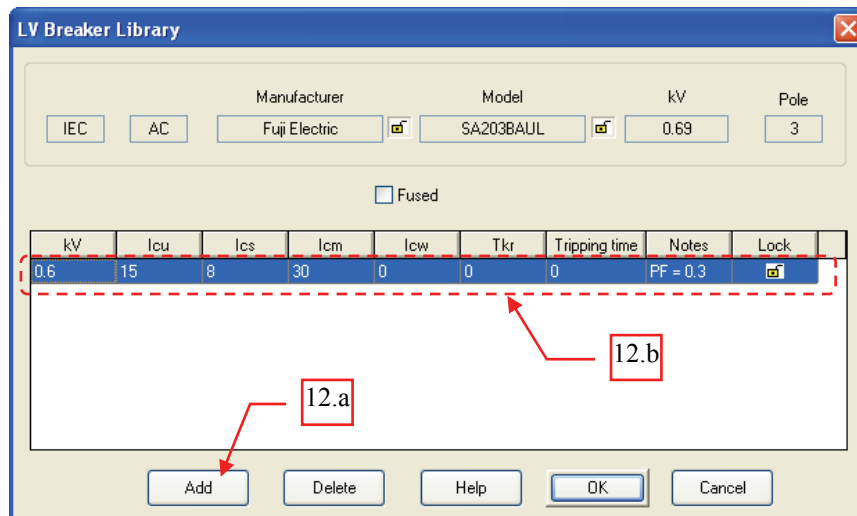

Fig. 11

ETAP TECHNICAL INFORMATION POINTERS

Table II (IEC947-2)

Short-circuit breaking capacity I^* (amperes) (kA)(r.m.s)			Power factor	Minimum value required for n $n = \frac{\text{Short-circuit making capacity}}{\text{Short-circuit breaking capacity}}$
4.5	$< I^{**} \leq$	6	0.7	1.5
6	$< I^{**} \leq$	10	0.5	1.7
10	$< I^{**} \leq$	20	0.3	2.0
20	$< I^{**} \leq$	50	0.25	2.1
50	$< I^{**}$		0.2	2.2

* I = any value of short-circuit breaking capacity.
 ** For lower values of breaking capacity, for certain applications see Table XI (Sub-clause 8.3.2.2.4) for the power factor.

13. Register the rest of the short circuit information at different voltage level given in Table 1, page 1 by similarly doing Step 12.

Note: You can right-click a row to copy short circuit information and paste to another row

14. The end result is similar to Fig. 13. Click the “OK” button when complete.

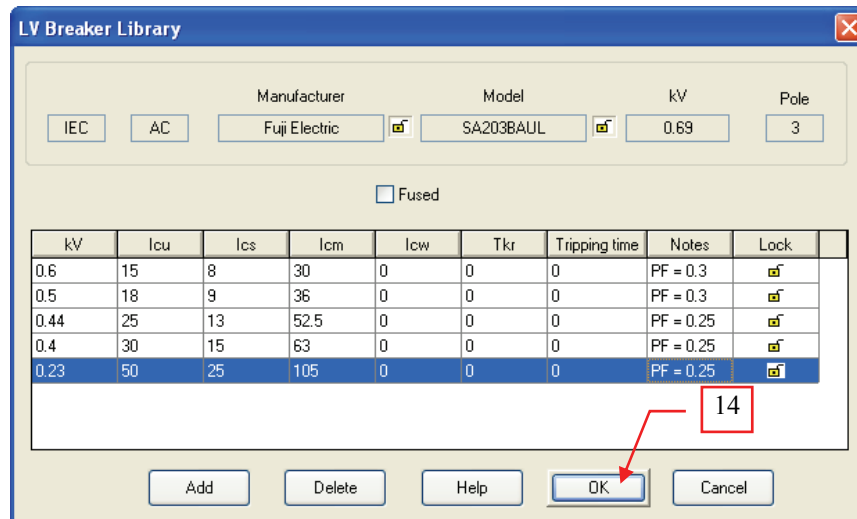

Fig. 13

15. Click the “Close” button in the “IEC LV Breaker Library – Molded Case” dialog box.

16. In the main menu, select “Library→Save” to save the changes.

17. End of Phase 1

II. Phase 2: Registering the Trip Unit (Characteristic Curve)

1. According to Table 1, page 1, the trip unit of the MCCB is a “Thermal-Magnetic” type.
2. From main menu, select “Library→Trip Device→Thermal Magnetic...”

The “LV Breaker Library” dialog box will be displayed.

3. In the “Manufacturer” frame of the “Thermal Magnetic Library” dialog box, click the “Add...” button. See Fig. 14.

The “Thermal Magnetic Library: Add” dialog box will be displayed.

Note: click the “Add” button only if the manufacturer is not yet available on the list box. Otherwise, just select the manufacturer.

4. Enter the following on the “Thermal Magnetic Library: Add” dialog box and click the “OK” button. See Fig. 15.

Manufacturer : Fuji Electric
 Reference : “leave blank” (no info.)
 Link : “leave blank” (no info.)

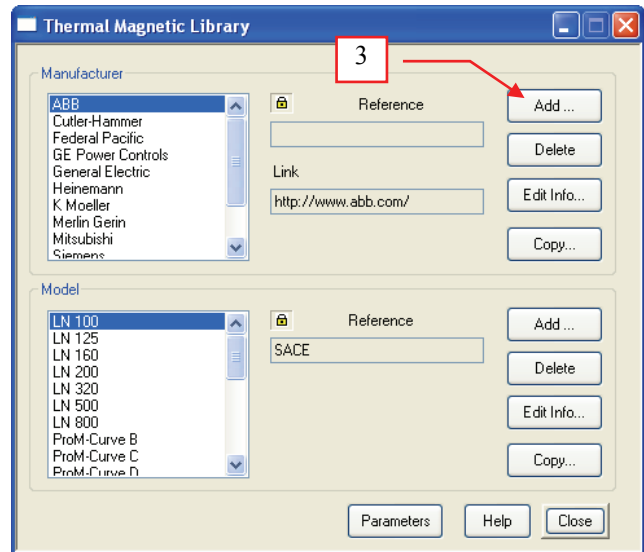

Fig. 14

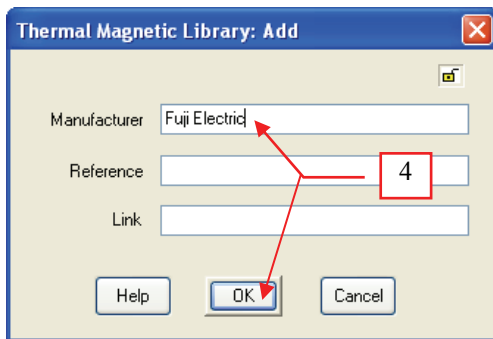

Fig. 15

5. With the “Fuji Electric” selected in the list box of the “Manufacturer” frame, click the “Add...” button in the “Model” frame. See Fig. 16

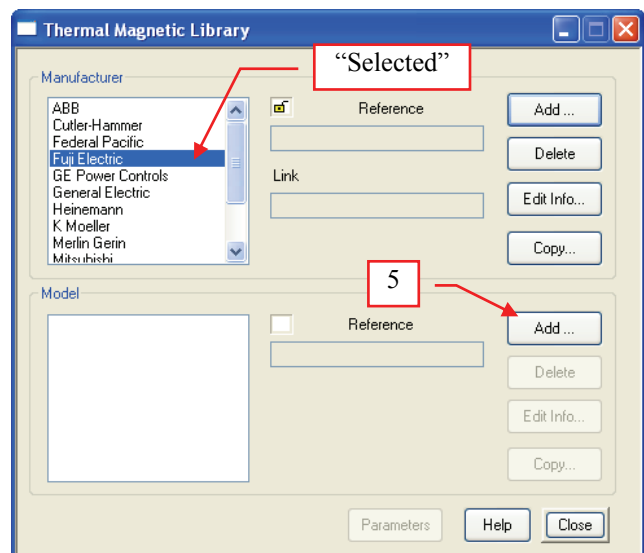

Fig. 16

ETAP TECHNICAL INFORMATION POINTERS

6. On the “Thermal Magnetic Library: Add” dialog box, do the following (see Fig. 17):

a. Enter the following information

Model : SA203BAUL
 Reference : SA Breaker
 Description : Fixed Thermal-Magnetic trip unit for SA202BAUL, SA203BAUL, SA202RAUL, SA203RAUL
 Link : “leave blank” (no info.)

b. Click the “OK” button

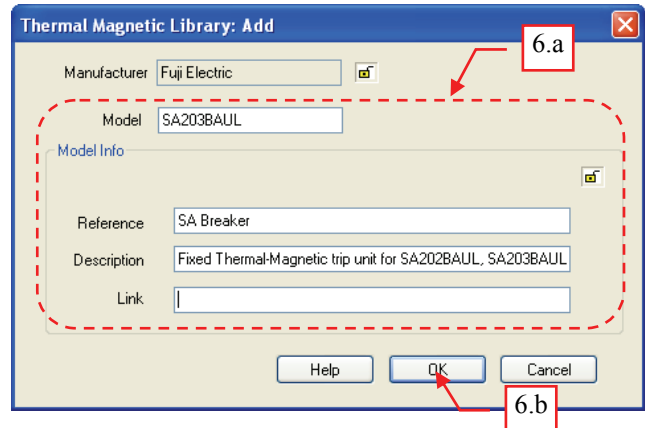

Fig. 17

7. With the “SA203BAUL” selected in the “Model” frame of the “Thermal Magnetic Library” dialog box, click the “Parameters” button. See Fig. 18

The “Thermal Magnetic Library: Parameters” will be displayed.

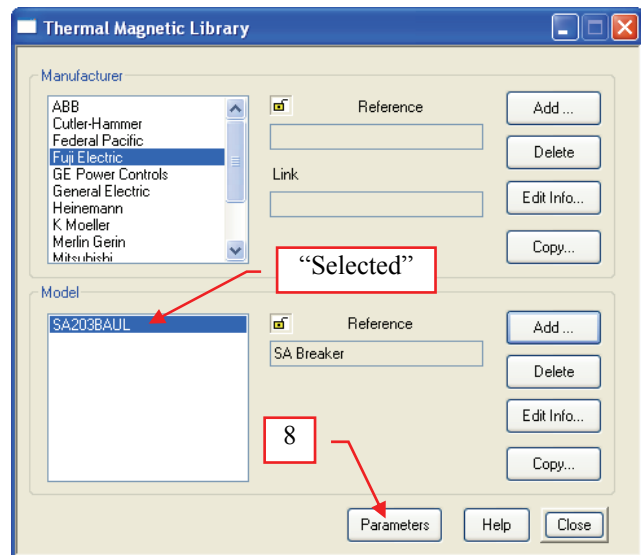

Fig. 18

ETAP TECHNICAL INFORMATION POINTERS

8. Guided by the information in Table 1 and Fig. 1a, page 1; In the “Rating” frame of the “Thermal Magnetic Library: Parameters” dialog box, do the following (see Fig. 19):
 - a. Click the “Add...” button.
 - b. Click the cell under “TM ID” column and type “225”
Note: If “ID” is not defined explicitly by the manufacturer, you could take the TM ID the same as the size (rated current)
 - c. Click the cell under the “Amps” column and type “225”
9. Between the radio buttons “Amperes” and “Multiples”, select “Multiples” since the characteristic curve is expressed in multiple of rated current (see Fig. 19)
10. Click the “Thermal” tab.
11. Check the “Thermal” checkbox since the trip characteristic contains thermal element
12. On the left side of the “Thermal” frame is a table for the points of the “Thermal Minimum Trip Curve”. Enter all the 15 points given in column “Curve A of Table 2: Locus of Points” on page 13 by doing the following sequentially:
 - a. Click the “Add...” button.
 - b. Click the cell under “Time(s)” column and type the value
 - c. Click the cell under “Mult Min” column and type the value

Note: You can copy and paste data from the spreadsheet program (e.g. MS Excel) to this table.

13. On the Right side of the “Thermal” frame is a table for the points of the “Thermal Maximum Trip Curve”. Enter the all 15 points given in column “Curve B of Table 2: Locus of Points” on page 13 by doing the similar actions performed in Step 12.

14. Click the “Temp Shift” button.

The “Trip Device Library: Temp. Shift Factor” will be displayed

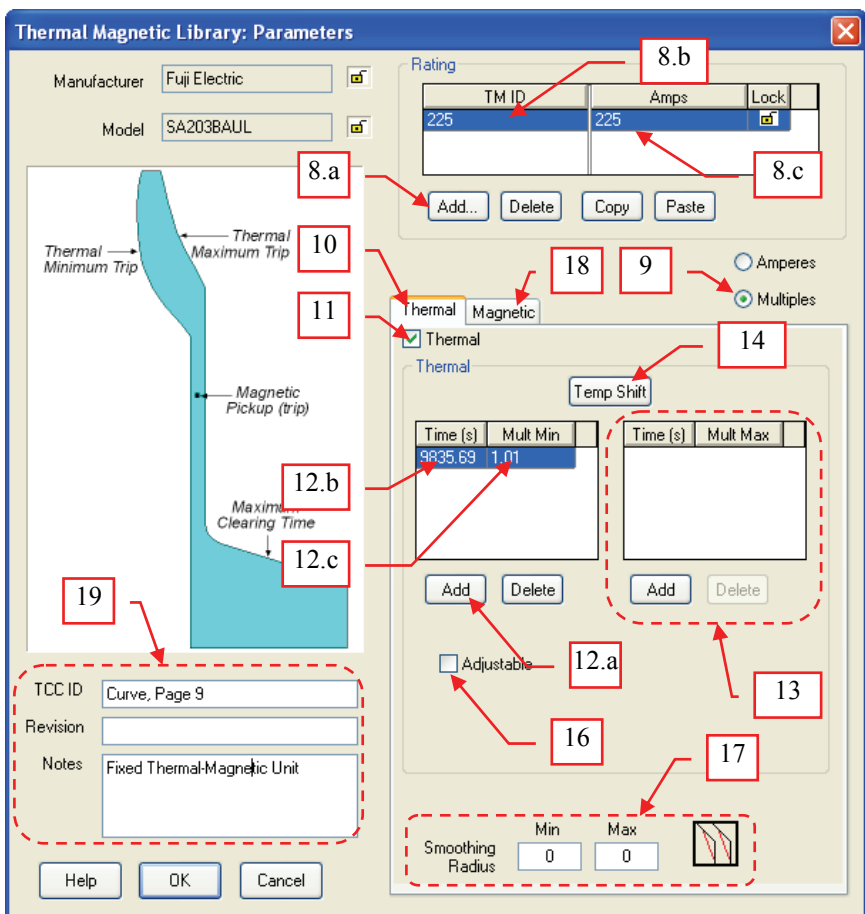

Fig. 19

15. In the “Trip Device Library: Temp. Shift Factor” dialog box, populate the table as shown in Fig. 20 by clicking on the appropriate cell and typing the numerical value. Also, click on the “Add” or “Delete” button when necessary. When finished, click the “OK” button.

Note: The values on the table were read and obtained from Fig. 1b on page 1.

16. Leave the “Adjustable” check box unchecked since the thermal element is fixed. See Fig. 19
17. Leave the Smoothing Radius “Min” and “Max” to zero because these have no effect on the curves since the thermal curves were defined by points. See Fig. 19
18. Click the “Magnetic” tab (see Fig. 19). The “Magnetic” page will be displayed as shown in Fig. 21. Do the following on this page:

- Check the “Magnetic” checkbox since the trip characteristic contains magnetic element
- Select “Fixed” radio button since the magnetic element is fixed
- Enter the following at the “Trip” row

Min : 8
Max : 14

Note: The above values were read from the characteristic curve in Fig. 1a on page 1.

- At the “Band” frame, select Define By “Points” radio button.

Note: If the magnetic element is fixed, the Define By “Points” is appropriate in general.

- Click the “Opening – Clearing Curve” button.

The “Thermal Magnetic Library: Magnetic Band Points” will be displayed.

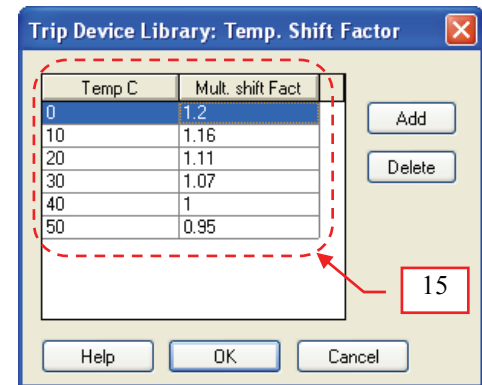

Fig. 20

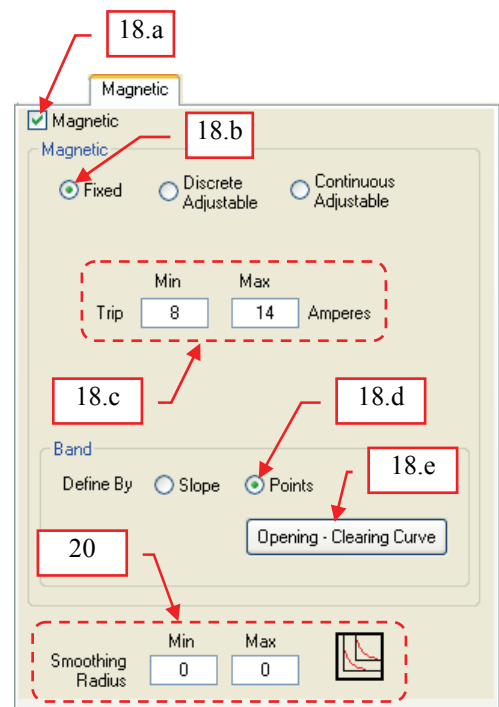

Fig. 21

19. In the “Thermal Magnetic Library: Magnetic Band Points” dialog box, do the following (see Fig. 22):

- a. In the “Opening Curve” frame, enter the 11 points given in column “Curve C of Table 2: Locus of Points” on page 13 by doing the similar actions performed in Step 12.
- b. Similarly, in the “Clearing Curve” frame (see Fig. 22), enter the 11 points given in column “Curve D” of “Table e: Locus of Points” on page 13.
- c. Click the “OK” button when complete.

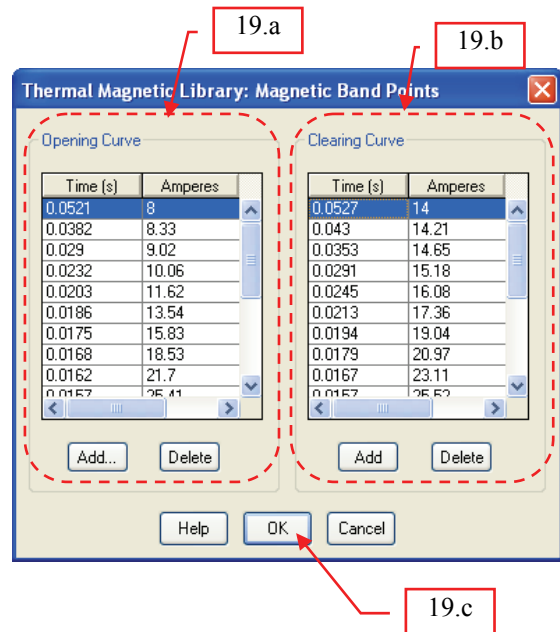

Fig. 22

20. Leave the Smoothing Radius “Min” and “Max” to zero because these have no effect on the curves since the Band curves were defined by points. See Fig. 21.

21. On the lower-left portion of the “Thermal Magnetic Library: Parameters” dialog box, enter the following information on the appropriate textbox (see Fig. 19):

TCC ID : Curve, Page 9 *
 Revision: “leave blank” (no info)
 Notes : Fixed Thermal-Magnetic Unit

* If no TCC ID is specified in the catalog, enter a concise identification to easily point out where the parameters and curves were read from.

22. At this point, the characteristic curve for the “225” rating unit is completed.

ETAP TECHNICAL INFORMATION POINTERS

23. The characteristic curve in Fig 1a, page 1 is common in all rating [125A, 150A, 175A, 200A, 225A]. Since the “225” rating has already been registered, you may just copy this one to complete the rest. See Fig. 23.

- a. In the “Rating” frame, click “Add...”
- b. Move the mouse to the 1st record (row) and click “Copy” button.
- c. Move and click the mouse to the 2nd record and click “Paste” button.
- d. Change the data on the 2nd record as follows:
 TM ID: to “125”
 Amps : to “125”
- e. Repeat the above steps similarly to complete the remaining ratings.

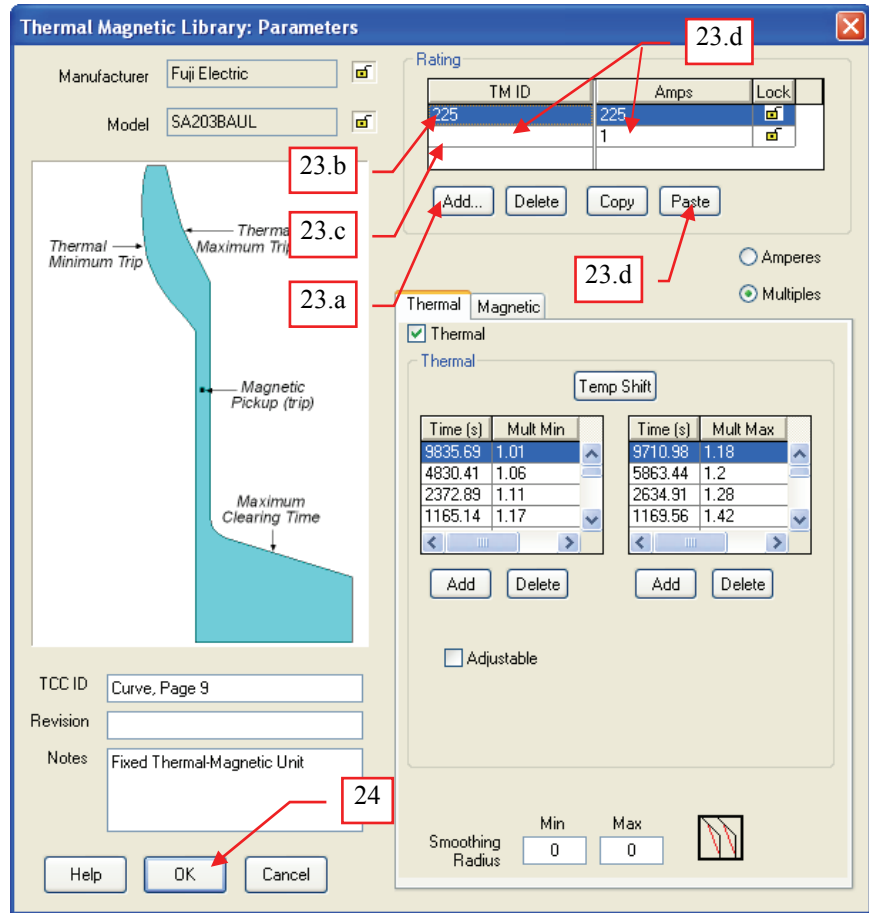
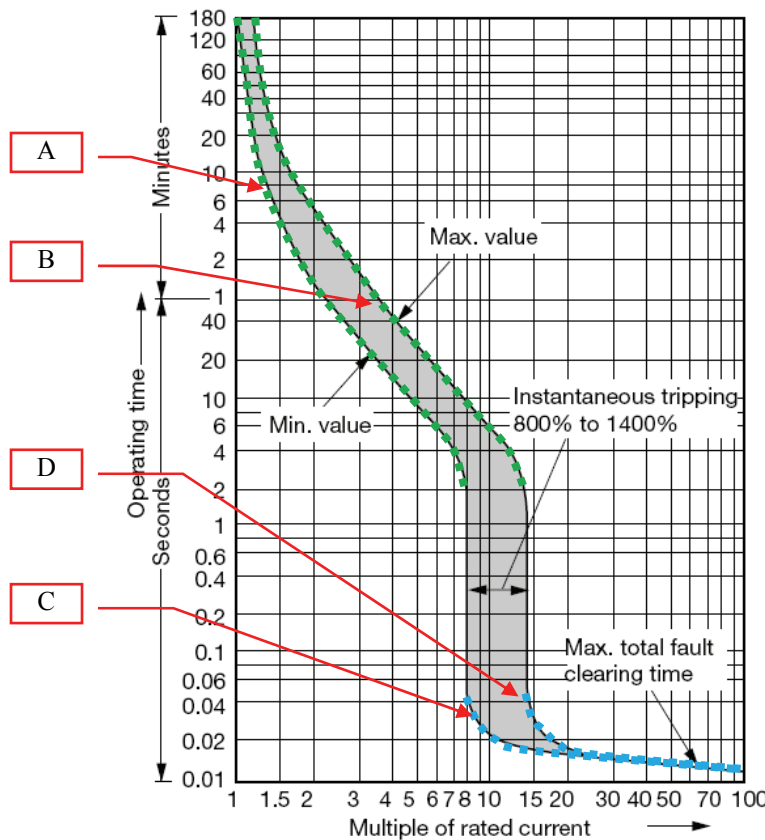

Fig. 23

24. Click the “OK” when complete (see Fig. 23).
25. Click the “Close” button to close the “Thermal Magnetic Library” dialog box.
26. In the main menu, **select** “Library→Save” to save the changes.
27. End of Phase 2.

ETAP TECHNICAL INFORMATION POINTERS



Curve “A” – is the thermal element minimum value that terminates to the point of intersection at the minimum value of the instantaneous element (vertical line).

Curve “B” – is the thermal element maximum value that terminates to the point of intersection at the maximum value of instantaneous element (vertical line)

Curve “C” – is the opening curve of the band of the instantaneous element that originates from the point of intersection at the minimum value of the instantaneous element (vertical line)

Curve “D” – is the clearing curve of the band of the instantaneous element that originates from the point of intersection at the maximum value of the instantaneous element (vertical)

See Table 2 for the locus of points of the respective curves.

Table 2: Locus of Points

	CURVE							
	A		B		C		D	
	Y	X	Y	X	Y	X	Y	X
Pt 1	9835.69	1.01	9710.98	1.18	0.0521	8.00	0.0527	14.00
Pt 2	4830.41	1.06	5863.44	1.20	0.0382	8.33	0.0430	14.21
Pt 3	2372.89	1.11	2634.91	1.28	0.0290	9.02	0.0353	14.65
Pt 4	1165.14	1.17	1169.56	1.42	0.0232	10.06	0.0291	15.18
Pt 5	581.52	1.28	532.04	1.69	0.0203	11.62	0.0245	16.08
Pt 6	296.68	1.45	267.05	2.15	0.0186	13.54	0.0213	17.36
Pt 7	154.27	1.68	79.93	3.30	0.0175	15.83	0.0194	19.04
Pt 8	83.08	2.02	35.46	4.55	0.0168	18.53	0.0179	20.97
Pt 9	19.71	3.65	4.60	11.36	0.0162	21.70	0.0167	23.11
Pt 10	6.31	6.08	3.85	12.17	0.0157	25.41	0.0157	25.52
Pt 11	5.17	6.64	3.14	12.74	0.0120	100.00	0.0120	100.00
Pt 12	4.14	7.15	2.55	13.25	-	-	-	-
Pt 13	3.26	7.57	2.05	13.60	-	-	-	-
Pt 14	2.53	7.90	1.65	13.89	-	-	-	-
Pt 15	1.95	8.00	1.32	14.00	-	-	-	-

Y – Vertical Axis (time in sec), X – Horizontal Axis (Multiple of rated current)

Fig. 24

III. Phase 3: Associating the Breaker to the Trip Unit

1. From main menu, select “Library→LV Circuit Breaker...”
2. In the “[X] LV Breaker Library – [Y]” dialog box, do the following (see Fig. 25):
 - a. In the “Type” pull down box, select “Molded Case”
 - b. In the “Standard” frame, select “IEC” radio button.
 - c. Between the AC and DC radio buttons, select “AC”
 - d. In the “Manufacturer” frame, select “Fuji Electric”.
 - e. In the “Model” frame, select “SA203BAUL”
 - f. Click “Assign Trip Device...”

The “LV Breaker Library” dialog box will be displayed

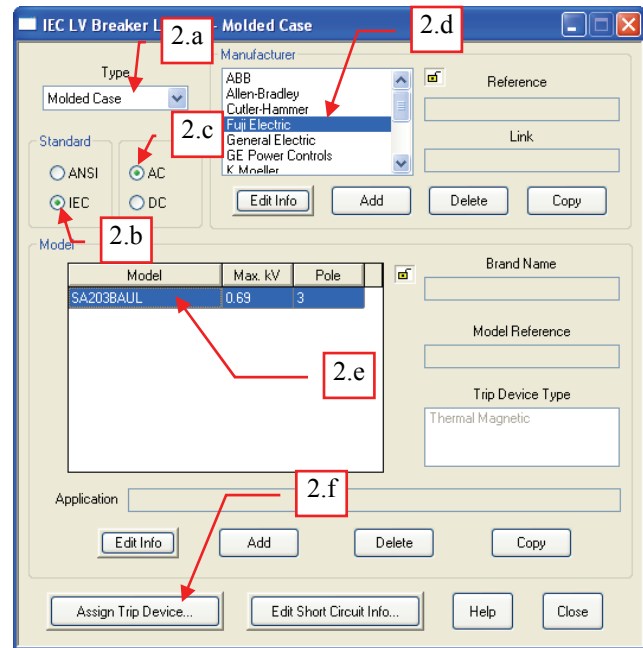

Fig. 25

3. In the “LV Breaker Library” dialog box, do the following (see Fig. 26):
 - a. In the “Size” frame, click the “Add” button.
 - b. Click the cell under “Amps” column, type “225”
 - c. Click the cell under “Notes” column and type “Fixed Thermal Magnetic”.

Note: The moment you click on this cell, ETAP will search the library database for available trip units. The table in the “Available” frame will be populated with the available trip device models and the corresponding sizes from the same manufacturer.

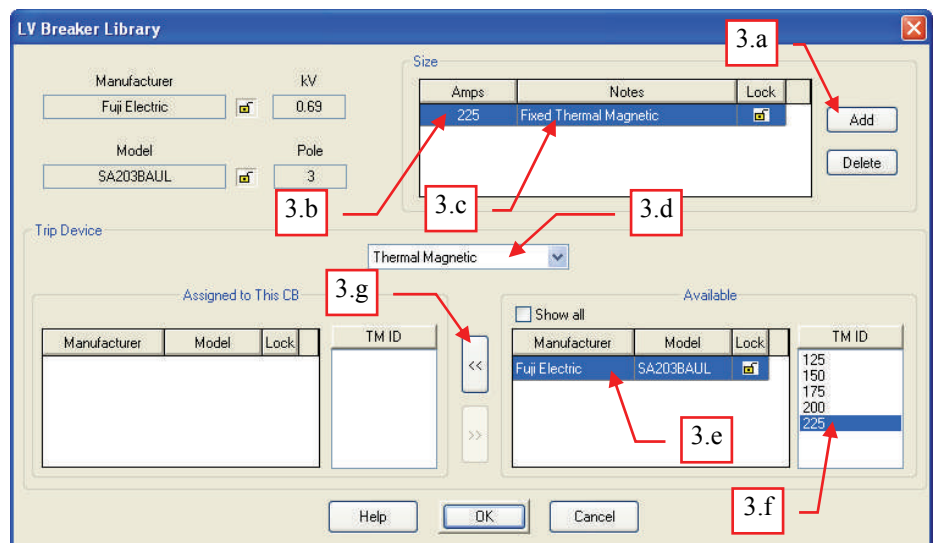

Fig. 26

ETAP TECHNICAL INFORMATION POINTERS

d. In the “Trip Device” frame, select “Thermal Magnetic”.

Note: Only “Thermal Magnetic” trip unit is available for this breaker since this is the only trip unit that was specified in Phase 1, Step 10.d (see Fig. 9).

e. In the “Available” frame, left table, select the row “Fuji Electric ; SA203BAUL”.

Note: By default, ETAP lists the available trip device model from the same manufacturer as that of the breaker. Since other trip units with retrofit kits may be used with a variety of breakers, it is possible to select trip units from other manufacturer by checking the “Show All” checkbox.

f. In the “Available” frame, right table, select the TM ID “225”.

g. Click the “ << ” button

4. Similarly, repeat the procedure in Step 3 to add following breaker sizes and their corresponding trip devices.

Breaker Size	TM ID
125	125
150	150
175	175
200	200

5. The end result is similar to Fig. 27.

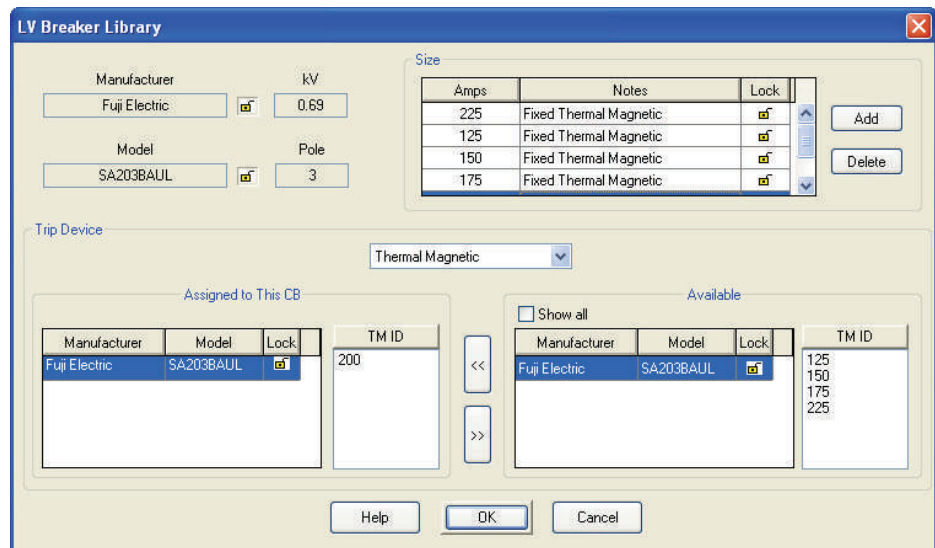

Fig. 27

6. Click the “OK” button when complete.

7. Click the “Close” button on the “IEC LB Breaker Library – Molded Case” dialog box.

8. In the main menu, select “Library→Save” to save the changes.

9. End of Phase 3.

B. Plotting the characteristic curve on TCC for verification

1. Click on the “One Line Diagram”  icon on the “Systems” toolbar (Vertical toolbar normally located on the left side of the window/screen).

2. Switch to edit mode by clicking the “Edit”  icon on the “Mode” toolbar.

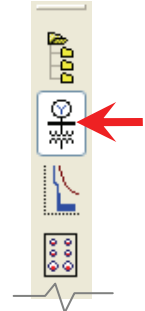
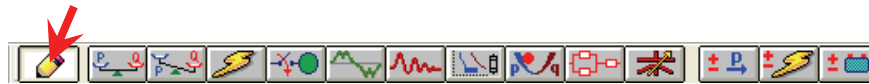

3. Add an LV Circuit breaker on the one line diagram presentation (See Fig. 28).

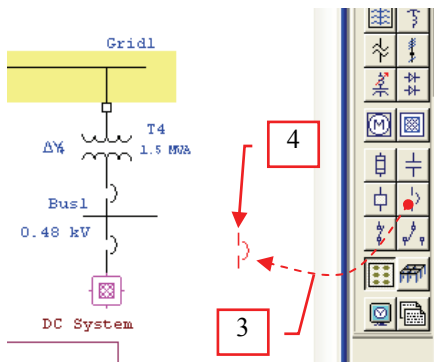

Fig. 28

4. Double click on the LV Circuit breaker symbol (See Fig. 28).

The “Low Voltage Circuit Breaker Editor – [X]” dialog box will be displayed ([X] – refers to the ID of the circuit breaker under consideration).

5. In the “Low Voltage Circuit Breaker Editor – [X]” dialog box, do the following (see Fig. 29):

- a. Click the “Rating” tab
- b. In the “Standard” frame, select “IEC” radio button.
- c. In the “Type” frame, select “Molded Case”
- d. In the “CB & Trip Device Library” frame, click the “Library...” button.

The “Library Quick Pick – LV Circuit Breaker” dialog box will be displayed.

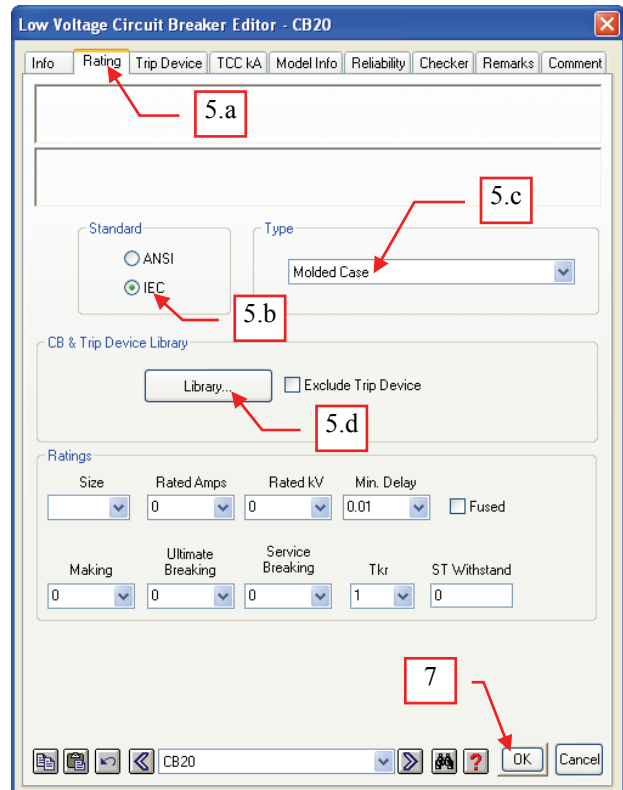

Fig. 29

6. In the “Library Quick Pick – LV Circuit Breaker” dialog box, do the following (see Fig. 30):
 - a. In the “Manufacturer” frame, select “Fuji Electric”.
 - b. In the “Model” frame, select “SA203BAUL”.
 - c. In the “Short-Circuit Data” frame, select “0.6” record.
 - d. In the “Size (Amps)” frame, select “225”.
 - e. Click the “OK” button.

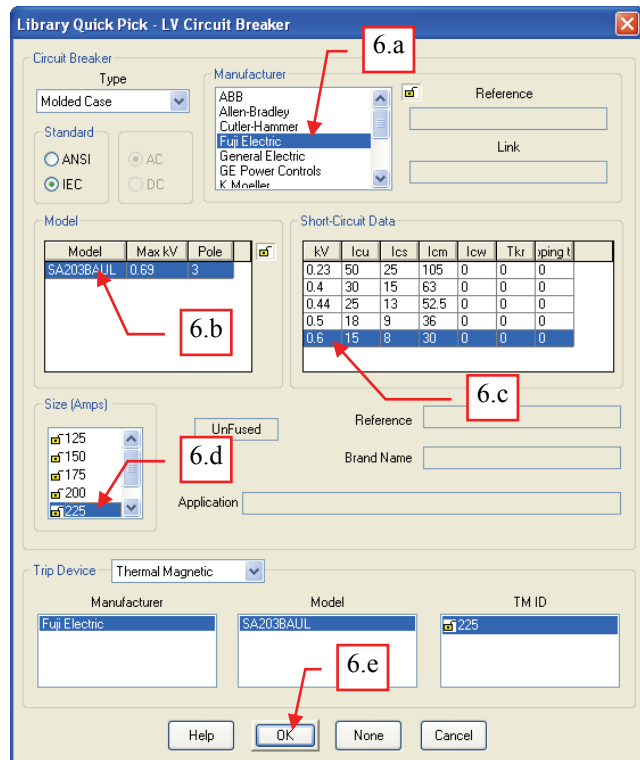



Fig. 30

7. Click the “OK” button in the “Low Voltage Circuit Breaker Editor – X” dialog box (See Fig .29).

8. Switch to “Protective Coordination” mode by clicking the “Star-Protective Coordination”  icon on the “Mode” toolbar.



9. Select the LV Circuit Breaker symbol added in Step 3.

10. Click the “Create Star View”  button on the “Star(PD Coordination)” toolbar (the vertical toolbar normally located on the right side of the window when the “Protection Coordination” mode is ctive).

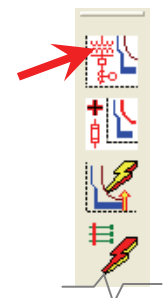

11. The TCC plot will be created similar to Fig. 31.

ETAP TECHNICAL INFORMATION POINTERS

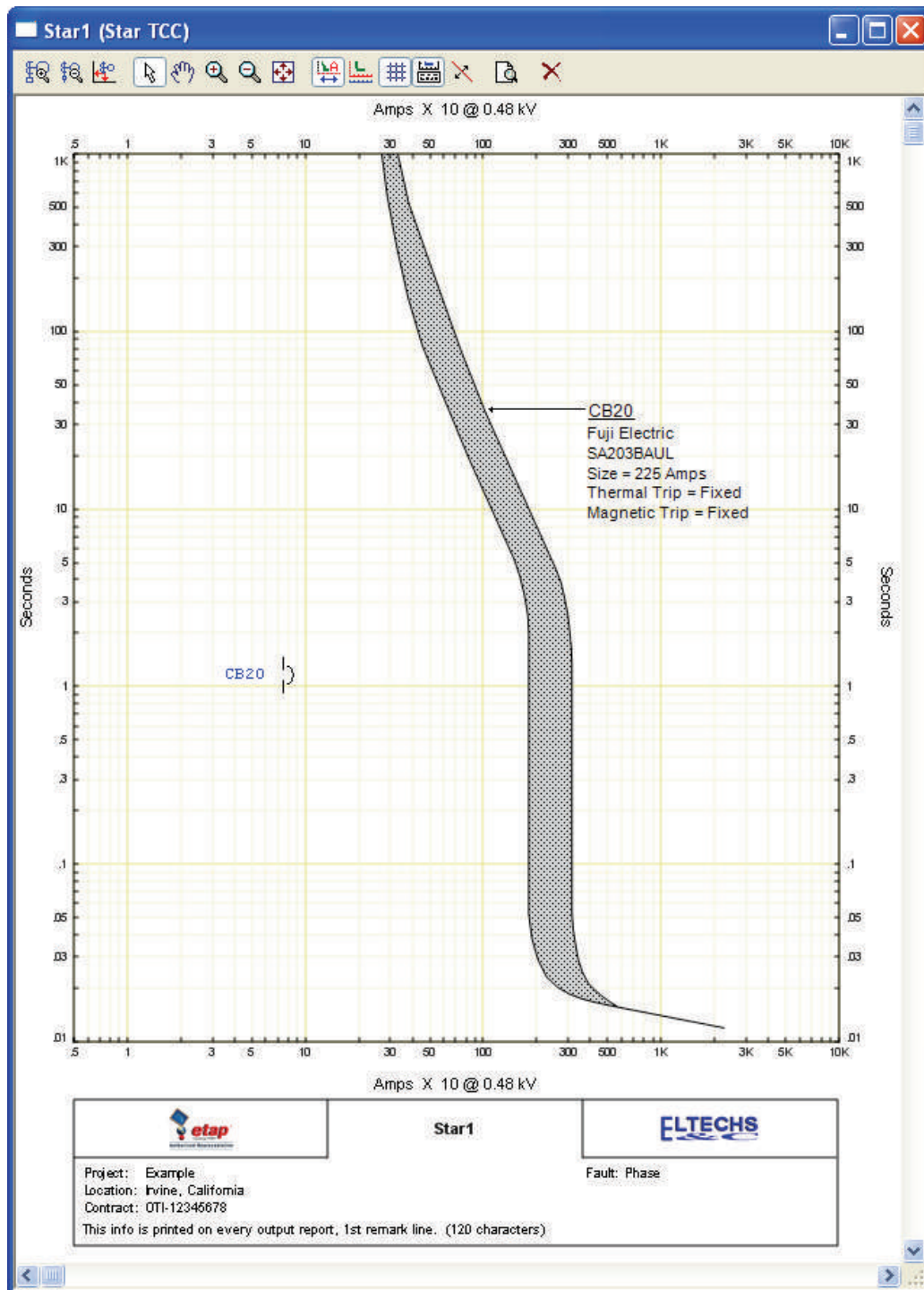

Fig. 31