

The Magazine Of  
The Institution Of Engineers, Singapore

March 2012 MICA (P) 069/02/2012



[www.ies.org.sg](http://www.ies.org.sg)

# THE SINGAPORE ENGINEER

COVER STORY:

POWER GENERATION

An environment-conscious power generation company





Innovative semiconductor solutions  
for energy efficiency, mobility  
and security



**WE CHANGE THE WORLD** by making people more independent of time, space and limitations. We are a global player in the area of microelectronics – one of the key technologies for today and tomorrow. We ask questions. Through our innovative semiconductor and system solutions we address three central challenges to modern society: energy efficiency, mobility and security. Infineon team members worldwide co-operate to turn ideas into answers of the future.

Details of the positions are available via [www.infineon.com/careers/singapore](http://www.infineon.com/careers/singapore)

Infineon Technologies AG, Neubiberg, Germany, offers semiconductor and system solutions addressing three central challenges to modern society: energy efficiency, mobility, and security. In the 2010 fiscal year (ending September 30), the company reported sales of Euro 3.295 billion with approximately 26,650 employees worldwide. With a global presence, Infineon operates through its subsidiaries in the U.S. from Milpitas, CA, in the Asia-Pacific region from Singapore, and in Japan from Tokyo. Infineon is listed on the Frankfurt Stock Exchange (ticker symbol: IFX) and in the USA on the over-the-counter market OTCQX International Premier (ticker symbol: IFNNY).

[www.infineon.com](http://www.infineon.com)

# CONTENTS

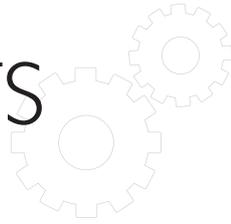

## FEATURES

- 13 **POWER GENERATION: Cover Story:**  
An environment-conscious power generation company  
Senoko Energy has taken proactive efforts towards achieving energy- and water-efficiency and reducing its carbon footprint, whilst continuing to be a competitive electricity supplier.
- 16 **POWER GENERATION: Interactive objectives and constraints between microgrid elements of the smart grid**  
The increasing complexity due to different power supply options and varying demand scenarios is addressed.
- 28 **RENEWABLE ENERGY:**  
Panasonic affirms commitment to solar technology  
Superior technology and products have led to an impressive track record of projects.
- 31 **SUSTAINABILITY: The 'Green Mark Tool' - a new outlook towards Green Mark projects**  
A new software solution for the design of green buildings is presented.
- 35 **PROJECT APPLICATION: Lighting control systems for Hong Kong residential development**  
The ability to adjust the lighting in the buildings ensures aesthetics, comfort, and impressive external views, whilst also contributing to energy conservation.
- 36 **PROJECT APPLICATION: The Hive**  
The Paris-based global headquarters of Schneider Electric became the world's first building to obtain the new ISO 50001 certification for energy management systems.
- 40 **INTERVIEW: An innovative model for engineering education**  
Autodesk recognises the importance of creative minds acquiring software skills at an early age.

## REGULAR SECTIONS

- 02 IES UPDATE
- 12 IES ACADEMY UPDATE
- 38 PRODUCTS & SOLUTIONS
- 42 EVENTS
- 44 NEWS

Chief Editor

T Bhaskaran  
[t\\_b\\_n8@yahoo.com](mailto:t_b_n8@yahoo.com)

Director, Marketing

Roland Ang  
[roland@iesnet.org.sg](mailto:roland@iesnet.org.sg)

Marketing & Publications Executive

Jeremy Chia  
[jeremy@iesnet.org.sg](mailto:jeremy@iesnet.org.sg)

CEO

Angie Ng  
[angie@iesnet.org.sg](mailto:angie@iesnet.org.sg)

Publications Manager

Desmond Teo  
[desmond@iesnet.org.sg](mailto:desmond@iesnet.org.sg)

Published by

The Institution Of Engineers, Singapore  
70 Bukit Tinggi Road  
Singapore 289758  
Tel: 6469 5000 Fax: 6467 1108

Cover designed by Irin Kuah  
Cover image by Senoko Energy

The Singapore Engineer is published monthly by The Institution of Engineers, Singapore (IES). The publication is distributed free-of-charge to IES members and affiliates. Views expressed in this publication do not necessarily reflect those of the Editor or IES. All rights reserved. No part of this magazine shall be reproduced, mechanically or electronically, without the prior consent of IES. Whilst every care is taken to ensure accuracy of the content at press time, IES will not be liable for any discrepancies. Unsolicited contributions are welcome but their inclusion in the magazine is at the discretion of the Editor.

Design & layout by 2EZ Asia Pte Ltd  
Printed by Print & Print Pte Ltd.



## Message from the President

Dear Friends,

With continued population growth and economic development, the world's requirement for energy will increase rapidly over the coming years. And the tight supply scenario for oil will only serve to push up the prices.

Countries are therefore evaluating and implementing various strategies for energy security and cost stability, which include diversifying their energy sources.

The abundance and widespread availability of coal makes it a viable option, however, its negative environmental impact is a major disadvantage. Concerted efforts are understandably being made to develop technologies that overcome this limitation.

For the power generation sector, these have been the considerations in the shift away from coal and oil and towards Natural Gas.

Power generation companies have embarked on repowering programmes using natural gas and more efficient generation systems and equipment.

Further, the companies have also incorporated energy-efficient technologies such as those for waste heat utilisation, as well as water-efficient technologies involving the use of reclaimed water and desalinated water.

These measures have contributed to a reduction in carbon emissions and the conservation of precious potable water resources.

For the energy sector, the coming on-stream, in 2013, of Singapore's first liquefied natural gas (LNG) terminal, located on Jurong Island, will be a welcome development.

The facility will consist of three tanks, and three jetties and it will have a throughput capacity of up to 6 million tonnes per annum.

The LNG terminal will allow Singapore to import gas from countries all over the world, thereby ensuring a stable supply of fuel to meet the country's rising energy needs. At the same time, it will help to reduce the carbon footprint of the sector.

In addition to organizing APCChE 2012 last month, IES also hosted the APCChE Council meeting as well as the World Chemical Engineering Council (WCEC) meeting during the conference period, with a very involving BBQ networking session.

Last month also saw IES's very own Marine and Offshore Technology Interest Group (MOTIG), together with the Centre for Offshore Research Engineering (CORE), organising the Maritime Symposium, with speakers sharing information on industry growth. It was a very successful session and attracted a crowd of close to 200 professionals in the industry.

Coverage of both this year's APCChE and the Maritime Symposium can be found in this issue of the magazine.

The next IES Annual General Meeting will take place on 26 May 2012 and the notice for it will go out sometime in April. I hope to see many of our members there!



Er. Ho Siong Hin  
President

The Institution of Engineers, Singapore (IES)

## IES COUNCIL MEMBERS 2011/2012

### President

Er. Ho Siong Hin

### Deputy President

Prof Chou Siaw Kiang

### Vice Presidents

Er. Chong Kee Sen

Er. Edwin Khew

Mr Neo Kok Beng

Er. Ong Geok Soo

Er. Ong See Ho

### Honorary Secretary

Er. Ng Say Cheong

### Honorary Treasurer

Dr Boh Jaw Woei

### Assistant Honorary Secretary

Mr Oh Boon Chye, Jason

### Assistant Honorary Treasurer

Mr Kang Choon Seng

### Immediate Past President

Er. Dr Lee Bee Wah

### Past President

Er. Tan Seng Chuan

Er. A/Prof Foo Say Wei

Er. Ong Ser Huan

### Council Members

Er. Dr Chew Soon Hoe

Prof Er Meng Joo

Ms Fam Mei Ling

Er. Dr Ho Kwong Meng

Dr Ho Teck Tuak

Er. Jee Yi Yng

Er. Koh Beng Thong

Dr Kwok Wai Onn, Richard

Mr Lee Kwok Weng

Mr Lim Horng Leong

Er. Low Wong Fook

Er. Prof Ong Say Leong

Mr Tan Boon Leng, Mark

Er. Toh Siaw Hui, Joseph

*ce*

**Turning off the photocopier at the end of the workday  
saves 1.2%\* on energy and CO<sub>2</sub> emissions.**

*in*

**Switching on energy efficient  
lighting saves up to 75%.\*\***

*lu*

Potentially, your company could save up to 75%\*\* in energy costs and CO<sub>2</sub> emissions by switching to Philips Intelligent Sereno T5 office lighting solutions. Featuring luminaires with daylight-linking and presence-detecting control systems, the Intelligent Sereno T5 lighting solution begins saving energy the minute it is installed.

To find out more, simply call Philips lighting at (65) 6882 3564 or visit [www.lighting.philips.com.sg](http://www.lighting.philips.com.sg)

\* Based on 16-hour workday and typical photocopier energy usage of 56kWh/month if switched on continuously

\*\* A typical office building (2,000 m<sup>2</sup>) using older, less energy-efficient lighting technology could save 32,500 kg of CO<sub>2</sub> and €6,500 in running costs per year by upgrading to the latest lighting technology

Notes: Energy savings and pay back times may vary according to the solutions used.

**PHILIPS**

sense and simplicity

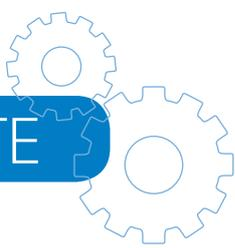

## IES ushers in The Year of Dragon with members

Nearly 140 IES members and their families celebrated the traditional IES Spring Festival and the arrival of the Year of the Dragon, on 3 February 2012, at IES Building.

The Chinese Lunar New Year was celebrated in the IES multi-purpose hall in rousing fashion. Everyone was dressed in their Chinese Lunar New Year's best. Good wishes were exchanged when all the members gathered at the dining tables, like a large family gathering. A lion dance troupe also performed with gusto and did some breathtaking stunts.

The traditional raw fish tossing (lohei) was done at every table before the sumptuous buffet dinner was served. Everyone present enjoyed the spread of food and tucked in heartily. IES President Er. Ho Siong Hin also went around each table to distribute gift bags that contained good luck mandarin oranges.

A highlight of the night was the Memorandum of Understanding that was signed between IES and the Institution of Occupational Safety and Health (IOSH) for the purposes of advancing and promoting the mutual interests of both parties, particularly in training as well as the continual education of engineering and workplace safety and health professionals.

Another highlight was the informative presentation by Ms Ramya Suryanarayanan of DBS on the topic 'Eurozone: Economic outlook and implications for Asia'.

After the talk, new IES members were also invited on stage to collect their certificates of membership. The evening ended on a happy note with a Hongbao draw.



A group shot of Council members before the celebration began.



Welcome speech by Er. Ho Siong Hin, President of IES.



MoU signing between Er. Ho (right) and Mr Harry Ho, Chairman of IOSH.



A lion dance ushered in a roaring Lunar New Year.



A talk on the Eurozone crisis was given by Ms Ramya Suryanarayanan of DBS Bank.



A high toss for fortune and prosperity in the Year of the Dragon.



HydroVision<sup>®</sup>  
INDIA

RENEWABLE  
ENERGY  
WORLD  
CONFERENCE & EXPO  
- INDIA -

# SWITCHING ON INDIA'S POWER FUTURE

19-21 APRIL 2012, PRAGATI MAIDAN, NEW DELHI, INDIA

Supported by Ministry of POWER, Government of India

## JOIN INDIA'S WORLD-CLASS POWER EVENT

Join India's world-class power event, POWER-GEN India & Central Asia together, Renewable Energy World India and HydroVision India, from 19-21 April 2012.

Featuring a world-class conference programme with discussions about topical issues, developments and benchmark projects plus a dynamic exhibition floor showcasing the very latest products and equipment serving the conventional, renewable and hydro power sectors all under one roof.

### MAJOR HIGHLIGHTS

- 120 eminent international chairs and speakers from around the globe
- 28 hot industry topics spanning over 8 conference sessions
- Over 200 exhibitors representing nearly 20 countries
- Proven track record attracting over 7,000 attendees
- Ample networking opportunities with the industry's most influential players
- Chance to find out about the latest technologies and product developments
- Prime platform to explore huge investment opportunities within the region

### EXHIBITION ENQUIRIES

#### POWER-GEN India & Central Asia

Kelvin Marlow  
Exhibit Sales Manager  
T +44 (0) 1992 656 610  
F +44 (0) 1992 656 700  
E kelvinm@pennwell.com

#### HydroVision India

Amanda Kevan  
Exhibit Sales Manager  
T +44 (0) 1992 656 645  
F +44 (0) 1992 656 700  
E amandak@pennwell.com

#### Renewable Energy World India

Virginia Willis  
Exhibit Sales manager  
T +44 (0) 1992 656 663  
F +44 (0) 1992 656 700  
E virginiaw@pennwell.com

### GENERAL ENQUIRIES

For further information, please visit:

[www.power-genindia.com](http://www.power-genindia.com) [www.hydrovisionindia.com](http://www.hydrovisionindia.com) [www.renewableenergyworldindia.com](http://www.renewableenergyworldindia.com)

Event Organizers



Flagship Media Sponsors



Supporting Organization



## APCChE Congress focuses on sustainable development and innovation

The 14<sup>th</sup> Asia Pacific Confederation of Chemical Engineering Congress (14<sup>th</sup> APCChE Congress) was held from 22 to 24 February 2012 at the Suntec Singapore International Convention and Exhibition Centre.

The event, which addressed the theme 'Sustainable Development through Innovation in Chemical Engineering', featured more than 480 plenary, keynote, oral, and poster presentations by speakers and authors from 23 countries. More than 800 delegates from Singapore and the region attended the congress.

Jointly organised by the Institution of Engineers, Singapore (IES), Singapore Chemical Industry Council (SCIC), Nanyang Technological University (NTU), and National University of Singapore (NUS), the 14<sup>th</sup> APCChE Congress was officially opened by Mr Manohar Khiatani, CEO of JTC Corporation.

In a Welcome Speech, Er. Edwin Khew, President of the 14<sup>th</sup> APCChE Congress 2012 and Vice President, IES, said that the theme for the event was extremely appropriate, considering these challenging times.

"Understanding climate change is a major concern of all global citizens. Chemical Engineers can step up, innovate and provide the sustainable solutions required by the world today", Er. Khew said.

In his Opening Address, Mr Khiatani spoke of the threats to the quality of the living environment and the need to address them.

"We cannot afford to remain ignorant about depleting resources and the impact of urbanisation on the environment. Faced with these challenges and the danger of global warming, it is critical to keep the delicate balance between economic progress and sustainable development", Mr Khiatani said.

He also highlighted the relevance of the 14<sup>th</sup> APCChE Congress and its theme in addressing these issues.

"Thus, it is important that we conduct such forums to review the impact of global changes. It is a very useful platform for chemical engineers such as yourselves to share your observations and expertise so that the knowledge can further spark ideas for innovative solutions to ensure that we can develop at a sustainable pace", Mr Khiatani said.

He pointed out that in the pursuit of sustainability, the Singapore government will utilise innovation to draw up policies, regulations, and incentives, but that it will also require the efforts of all sections of society.

"For us to succeed, we have to work together with innovative minds in the industry like yourselves, business leaders and our people and community at large to achieve sustainable development with a dynamic economy and a high quality living environment. Through innovation, we can improve on the way we use our key resources such as land, energy, and water, and invest in building new capabilities and testing new technologies", Mr Khiatani said.

Apart from the traditional academic programme, the congress also featured two sessions of critical importance to the chemical engineering industry, that addressed 'Sustainability in Practice' and 'Process Safety Management - Towards Zero-incident Operations'.

The session on 'Sustainability in Practice' focused on the various methodologies for cultivating a robust sustainability culture, with particular emphasis on developing visible management commitment, an appropriate organisational structure, and focused processes and actions.

The session on 'Process Safety Management - Towards Zero-incident Operations' provided participants with an understanding of the critical elements that are necessary for managing Process Safety, allowing practitioners to share their knowledge, experience and challenges encountered in achieving and sustaining zero-incident operation.



Er. Edwin Khew, President of the 14<sup>th</sup> APCChE Congress 2012 and Vice President, IES.



Mr Manohar Khiatani, CEO of JTC Corporation, the Guest-of-Honour at the Official Opening of the 14<sup>th</sup> APCChE Congress 2012.



14<sup>th</sup> APCChE Congress 2012 Organising Committee: First row, from left, Ms June C Wispelwey (AIChE); Prof David Wood, Australia - President, WCEC; Er. Edwin Khew (IES); and Greg Lewin (Australia).

Second row, from left, Mr Roland Andersson, Canada - WCEC; Andrew Furlong (IChemE); Engr. Cezar S De La Cruz (PIChE); Prof. Hwayong Kim (KICChE); and Dr David Brown (IChemE).

Third row, from left, Prof Liang-Shi Fan; Mr. Japie Scholtz, South Africa - WCEC; Prof Kouichi Miura (SCEJ); Dr Foo Swee Cheng (IES); and Ms Mohy Sharifi representing Prof Brent Young (SCENZ).

Fourth row, from left, Prof Cheng-Liang Chen representing Mr Shien-Chang Chen (IChECT); Dr Philippe A Tanguy (CSChE); Dr Willi Meier (DECHEMA); Prof David Shallcross (IChemE); Prof Mohd Ali Hashim (IEM); and Mr Russell Scott [Engineers Australia/IChemE (Aust)/RACI].



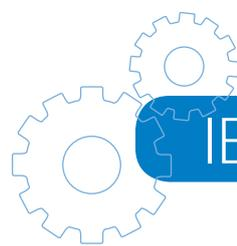

# Chevron Chem-E-Car Competition 2012

The Chevron Chem-E-Car Competition 2012, which was held on 21 February 2012, in conjunction with the 14<sup>th</sup> APCChE Congress, attracted over 20 participating teams, including international teams from Iran, Chinese Taipei, and Malaysia, and local teams from the Institutes of Higher Learning, junior colleges, and secondary schools.

The competition, staged in Singapore for the first time, was hosted by Singapore Polytechnic at its campus.

The Guest-of-Honour at the event was Er. Ho Siong Hin, President, IES.

In a Welcome Speech, Mr Tan Hang Cheong, Principal of Singapore Polytechnic said that the polytechnic was proud to contribute to the 14<sup>th</sup> APCChE Congress, by chairing the Chevron Chem-E-Car Competition and hosting the event at the polytechnic's campus.

In his Opening Address, Er. Ho said that the search for alternative and renewable sources of energy requires innovation, creativity, technical competence and analytical skills, as well as teamwork, planning, and project management skills.

"These are the qualities that the Chem-E-Car Competition aims to foster amongst our many participants", said Er. Ho.

"This student-based competition requires our participants to think 'out of the box' to design, construct and operate a prototype car powered by a chemical energy source", he added.



Er. Ho Siong Hin, President, IES.



Mr Tan Hang Cheong, Principal, Singapore Polytechnic.



Mr Lim Keng Yang, General Manager-Technical, Chevron Oronite Pte Ltd, the Exclusive Sponsor of the Chevron Chem-E-Car Competition 2012.



The Chem-E-Car Competition Organising Committee: from left, Mr Soon Seng Lee; Mr Mirko Stoll; Mr Lim Peng Hun, Deputy Principal, Singapore Polytechnic; Mr Yow Kum Pang; Mr Tan Hang Cheong, Principal, Singapore Polytechnic; Er. Ho Siong Hin, President of IES; Mr Lim Keng Yang, General Manager-Technical, Chevron Oronite Pte Ltd; Ms Angie Ng, CEO of IES; Dr Foo Swee Cheng, 14<sup>th</sup> APCChE Congress 2012 OC Chairman; Dr Thomas Chai Min Sen, Senior Director, Singapore Polytechnic; and Mr Tay Kheng Siong, Chairman of Chem-E-Car Competition.

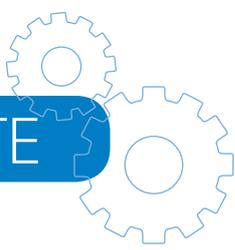

## The Winners

### INSTITUTIONS OF HIGHER LEARNING CATEGORY (OVERALL BEST PERFORMANCE)



1st Prize: Institution: Nanyang Polytechnic. Car: Scarlet Streak.



2nd Prize: Institution: University Teknologi Petronas. Car: Fast@UTP.



3rd Prize: Institution: Urmia University of Technology. Car: Samen.

### INSTITUTIONS OF HIGHER LEARNING CATEGORY (CAR PERFORMANCE I – PRECISION RACE)

#### 1st Prize

Institution: Nanyang Polytechnic - Car: Scarlet Streak

#### 2nd Prize

Institution: National University of Malaysia - Car: Greenie Energizer

#### 3rd Prize

Institution: University Teknologi Petronas - Car: Fast UTP

### INSTITUTIONS OF HIGHER LEARNING CATEGORY (CAR PERFORMANCE II – SPEED RACE)

#### 1st Prize

Institution: University Teknologi Petronas - Car: Furious@UTP

#### 2nd Prize

Institution: Nanyang Polytechnic - Car: FEZTMOBIL

#### 3rd Prize

Institution: University Teknologi Petronas - Car: Fast@UTP

## MOU between JTC Corporation and IES

On the sidelines of the 14<sup>th</sup> APCChe Congress, an MOU was signed between JTC Corporation (JTC) and IES, on 22 February 2012, as a result of which the two organisations will work together in engineering design development and related activities, with a view of promoting and facilitating innovative and sustainable industrial infrastructure solutions.

JTC will collaborate with IES to engage suitable IES Members and Fellows to take on relevant roles, such as Project Managers, in JTC development projects, on a contract service agreement basis.

JTC will also work with IES to form a Technical and Engineering Advisory Committee with suitable IES Members / Fellows, to review and provide inputs at the conceptual stage for selected JTC projects.

The MOU was signed by Mr David Tan, Asst Chief Executive Officer (TPG), JTC, and Er. Edwin Khew, Vice President, IES.



Er. Edwin Khew, Vice President, IES (second from left) and Mr David Tan, Asst Chief Executive Officer (TPG), JTC (third from left), after signing of the MOU. Looking on, are Prof Chou Siaw Kiang, Deputy President, IES, and Mr Manohar Khiatani, CEO of JTC.

## SCHOOLS CATEGORY (OVERALL BEST PERFORMANCE)



1st Prize: Institution: Si Ling Secondary School. Car: Pace Setter.



2nd Prize: Institution: Hwa Chong Institution. Car: Paws.



3rd Prize: Institution: Woodgrove Secondary School. Car: WGSoar.

### POSTER COMPETITION

1st Prize

Institution: Nanyang Polytechnic  
Car: FEZTMOBIL

2nd Prize

Institution: Urmia University of Technology  
Car: Samen

2nd Prize

Institution: Army Academy R.O.C.  
Car: Go-Go-Car



Invited guests and participants in the competition.

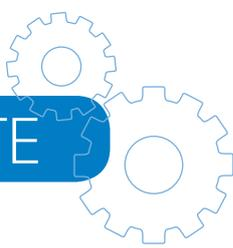

# Symposium discusses developments in the marine & offshore industry

The Maritime Symposium 2012 was held at National University of Singapore Engineering Auditorium, on the night of 22 February. Organised by IES Marine and Offshore Technology Interest Group (MOTIG) and Centre for Offshore Research Engineering (CORE), this inaugural event had an overwhelming response, with about 170 participants, among whom were Professional Engineers and engineers with qualifications in marine & offshore engineering as well as other engineering disciplines.

IES MOTIG invited a panel of speakers from the marine & offshore industry and government agencies to share their plans to support and expand the industry as well as present their current and future outlooks for the industry in Singapore and around the world.

Prof Choo Yoo Sang from CORE was the moderator for the Q&A session at which concerns were raised about the supply of suitably trained engineers and the image of the marine & offshore industry.

Some of the topics addressed by the speakers were:

- 'Growing the marine & offshore sector in Singapore - A general overview of the marine & offshore sector; followed by the key initiatives which EDB is undertaking to further develop the sector and position it for its next phase of growth', by Mr Lim Kok Kiang, Executive Director, Transport Engineering, Singapore Economic Development Board (EDB).
- 'SSA Offshore Industry's outlook for the next 5-10 years', by Mr Neil Glenn, Chairman, Offshore Services Committee, Singapore Shipping Association (SSA).
- 'Breaking New Ground in Industrial Infrastructure Solutions', by Mr Leow Thiam Seng, Director, Offshore and Marine Department, JTC Corporation.
- 'Introduction to SMI's goals, objective and plans for the immediate future', by Mr Heng Chiang Gnee, Executive Director, Singapore Maritime Institute.

At the end of the symposium, MOTIG Chairman, Mr Ng Sing Chan presented tokens of appreciation to the moderator and to all the speakers.



Mr Lim Kok Kiang, Executive Director, EDB.



Mr Neil Glenn, Chairman of Offshore Services Committee, SSA.



Mr Leow Thiam Seng, Director, Offshore and Marine Dept, JTC Corporation.



Mr Heng Chiang Gnee, Executive Director, Singapore Maritime Institute.



Prof Choo Yoo Sang (middle) and the panel of speakers during the moderated Q&A session.



MOTIG Chairman, Mr Ng Sing Chan, gave a welcome address to the audience.



The audience at the symposium.

## US Department of Defence Official visits IES

Mr Stephen Welby, Deputy Assistant Secretary of Defence (Systems Engineering), US Department of Defence made a courtesy visit to IES on 9 March 2012 and was warmly welcomed by IES CEO, Ms Angie Ng. Apart from touring the office building, Mr Welby and his delegation were also given an introductory brief on IES and the various professional

activities organised for IES members.

Mr Lim Horng Leong, Chairman of the Systems Engineering Technical Committee, also gave a presentation on the IES Systems Engineering Certification. The visit ended with an enlightening discussion over a working lunch.



Mr Stephen Welby (4<sup>th</sup> from left) with IES President, Er. Ho Siong Hin (3<sup>rd</sup> from right)



IES CEO, Ms Angie Ng showing the guests around the building and giving a presentation on IES.

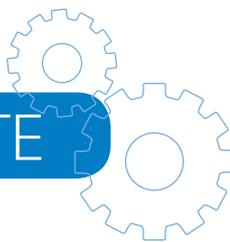

## IES Academy Planned Event 2012

(Pls refer [www.ies.org.sg](http://www.ies.org.sg) for details & Registration)

No.	Event Description	Dates to confirm	Accrediation	Contact
<b>Events for Resident Technical Officer / Engineers</b>				
1	RE/RTO - Welding Series (Module 1-10), 3 hours / module	Jan-Dec 2012 (7pm to 10pm)	3 STU, PDU	Karen, 6461 1239 karen@iesnet.org.sg
2	RE/RTO - Good Concrete Series (Module 1-5), 3 hours / module	To be advised later (7pm to 10pm)	3 STU, PDU	Vincent, 6461 1240 vincent@iesnet.org.sg
3	RE/RTO - Structural Steel Series (Module 1-3), 3 hours / module	To be advised later (7pm to 10pm)	3 STU, PDU	Vincent, 6461 1240 vincent@iesnet.org.sg
4	RE/RTO - Paired Natsteel Workshop & Law on Health & Safety, Environment, Corruption (Module 1-2), 7 hours	Jan-Dec 2012 (1pm to 10pm)	6 STU, 4 PDU	Vincent, 6461 1240 vincent@iesnet.org.sg
5	RE/RTO - Surveying Basic (Module 1-2), 3 hours / module	Jun, Jul, Sep 2012 (2pm to 9pm)	6 STU, PDU	Karen, 6461 1239 karen@iesnet.org.sg
6	RE/RTO - Turbidity Curtain	Jan, Apr, Jul, Oct 2012 (7pm to 10pm)	3 STU, PDU	Karen, 6461 1239 karen@iesnet.org.sg
7	RE/RTO - Guide to Stainless Steel	Feb, May, Aug, Nov 12 (7pm to 10pm)	3 STU, PDU	Karen, 6461 1239 karen@iesnet.org.sg
8	RE/RTO - Concrete, Inspection and Repair	Jan-Dec 2012 (3pm to 10pm)	6 STU, PDU	Karen, 6461 1239 karen@iesnet.org.sg
9	Certificate of Competency (CoC) in Earth Control Measures (ECM) for Construction Site Personnel	Apr, Jun, Aug, Oct 2012 (8:30am to 6pm)	6 STU, PDU	Rasheedah, 6461 1238 rasheedah@iesnet.org.sg
10	One Day Course on Working at Height	Jan-Dec 2012 (9-5:30pm/6:30-9:30)	6 STU, 7 PDU, 7 SDU	Samuel, 6461 1237 samuel@iesnet.org.sg
11	Risk Management Update with New Code of Practise	Jan-Dec 2012 (9-4:30pm/6:30-9:30)	6 STU, 6 PDU	Samuel, 6461 1237 samuel@iesnet.org.sg
<b>Events for Professional Engineers</b>				
12	Prestressed Concrete in Buildings	To be advised later (9am to 5pm)	PDU, STU (RE)	Rasheedah, 6461 1238 rasheedah@iesnet.org.sg
13	Preliminary Design of High-Rise Buildings	To be advised later (9am to 12:15pm)	PDU, STU (RE)	Rasheedah, 6461 1238 rasheedah@iesnet.org.sg
14	Strengthening of Reinforced Concrete Structures	To be advised later (1pm to 4:30pm)	PDU, STU (RE)	Rasheedah, 6461 1238 rasheedah@iesnet.org.sg
15	Design of Steel Structures and Joints To EC3 - <b>New</b>	14-15 May 2012 (9am to 6:00pm)	PDU, STU (RE)	Rasheedah, 6461 1238 rasheedah@iesnet.org.sg
16	Structural Engineering Failure	May 2012 (9:30am to 5:30pm)	PDU, STU (RE)	Rasheedah, 6461 1238 rasheedah@iesnet.org.sg
17	Elements of Laboratory BioSafety	To be advised later (9am to 5:30pm)	PDU	Rasheedah, 6461 1238 rasheedah@iesnet.org.sg
18	Elements of Internal Audit for Medical Device Industry	To be advised later (9am to 5:30pm)	PDU	Rasheedah, 6461 1238 rasheedah@iesnet.org.sg
19	3 Days Course on Design of Maritime Structure	To be advised later (9am to 6pm)	PDU	Karen, 6461 1239 karen@iesnet.org.sg
20	ABC Water Professional Course	May-Jun 2012 (9am to 5:30pm)	PDU, CPD, QCEP Registry	Rasheedah, 6461 1238 rasheedah@iesnet.org.sg
21	Introduction to the Petroleum Downstream Industry	To be advised later (9am to 5:30pm)	PDU	Samuel, 6461 1237 samuel@iesnet.org.sg
22	2 Days Course on Green Pump - Centrifugal	To be advised later (8:30am to 5:30pm)	PDU	Samuel, 6461 1237 samuel@iesnet.org.sg
23	Technical & Business Writing for Engineering Personnel	April 2012 (9pm to 6pm)	PDU	Samuel, 6461 1237 samuel@iesnet.org.sg
24	BIM Exploration Course - <b>New</b>	30 Jul - 1 Aug 2012 (9pm to 5pm)	PDU, STU	Samuel, 6461 1237 samuel@iesnet.org.sg
25	Design for Safety Appreciation Course - <b>New</b>	24 April 2012 (9pm to 6pm)	PDU, CPD, SDU, STU	Vincent, 6461 1240 vincent@iesnet.org.sg
<b>Funded Course</b>				
26	Qualified Erosion Professional Control (WDA Fundings), 39 hours Course	Sep-Nov 2012 (6:30pm to 9:30pm)	PDU, QCEP Registry	Samuel, 6461 1237 samuel@iesnet.org.sg
27	IES Certified System Engineering Management (WDA Fundings), 5 Full Days or 40 hours Course	To be advised later (9am to 6pm)	PDU, CSEP Registry	Samuel, 6461 1237 samuel@iesnet.org.sg
28	Singapore Certified Energy Manager - (Modules 1-6), 24 hrs/module (NEA Fundings)	Jan-Dec 2012 (9am to 6pm)	PDU, SCEM Registry	Nicholas, 6461 1238 nicholas@iesnet.org.sg
<b>Preparatory Course for Certification</b>				
30	Preparatory Course For Fundamentals Of Engineering Examinations - Civil Engineering	Apr-May 2012 (6:30pm to 9:30pm)	PEB: FEE Exam	Nicholas, 6461 1238 nicholas@iesnet.org.sg
31	Preparatory Course For Fundamentals Of Engineering Examinations - Mechanical Engineering	Jul-Sep 2012 (6:30pm to 9:30pm)	PEB: FEE Exam	Vincent, 6461 1240 vincent@iesnet.org.sg
32	Preparatory Course For Fundamentals Of Engineering Examinations - Electrical Engineering	Aug 2012 (6:30pm to 9:30pm)	PEB: FEE Exam	Vincent, 6461 1240 vincent@iesnet.org.sg
33	Geotechnical Engineering Appreciation Course (Modules 1-9), suitable for Professional and Resident Enginners	Jul-Aug 2012 (6:30pm to 9:30pm)	PDU, 3/6STU each, PE Specialist Exam	Nicholas, 6461 1238 nicholas@iesnet.org.sg
34	Workshop on Building Control Act & Regulations for Practicing Engineers	12 April 2012 (9:00am to 5:30pm)	7 PDU, STU	Rasheedah, 6461 1238 rasheedah@iesnet.org.sg

## An environment-conscious power generation company

Senoko Energy Pte Ltd (Senoko Energy) is currently the largest power generation company in Singapore, having a licensed capacity of 3,300 megawatts (MW) and providing about one quarter of the nation's electricity needs. Its subsidiary, Senoko Energy Supply Pte Ltd is a major electricity retailer.



Er. Eu Pui Sun.

Senoko Energy's ongoing efforts are aimed at producing electricity using processes with lower carbon emissions, and marketing it at competitive prices.

'The Singapore Engineer' meets with Er. Eu Pui Sun, Managing Director, Senoko Energy Supply Pte Ltd and Mr Kwong Kok Chan, Vice President (Environment & Quality), Senoko Energy Pte Ltd, and obtains more details.



Mr Kwong Kok Chan.

### Senoko Energy

Senoko Energy, formerly known as PowerSenoko Limited, commenced operations in 1976, as part of the generation division in the Electricity Department of the Public Utilities Board (PUB).

On 1 October 1995, as part of the corporatisation of the Electricity and Gas Departments of the PUB, PowerSenoko was established as a public company limited by shares and became a subsidiary of Singapore Power Limited (Singapore Power), to hold both Senoko Power Station and Pasir Panjang Power Station.

On 1 April 2001, Singapore Power divested its interest in PowerSenoko to Temasek Holdings and PowerSenoko was renamed Senoko Power Limited.

In September 2008, a consortium comprising GDF Suez of France and Japanese organisations Marubeni Corporation, The Kansai Electric Power Company, Kyushu Electric Power Company, and Japan Bank for International Cooperation, acquired Senoko Power Limited for S\$ 3.65 billion.

Senoko Power Limited was renamed Senoko Energy Pte Ltd in 2010. Senoko Energy was granted a generation licence to operate its plants at Senoko Power Station and Pasir Panjang Power Station. The operations of Senoko Energy have been certified to international standards ISO 9000, in 1998; OHSAS 18001, in 2003; and ISO 14001, in 2004.

### Plant portfolio

Senoko Energy's plant portfolio is split between its main site at Senoko Power Station and a separate site at Pasir Panjang

Power Station. The portfolio comprises a mix of oil-fired steam turbines, gas-fired combined cycle plant, and diesel-fired open cycle gas turbines.

Stage Two which was completed in 1979, comprises three oil-fired steam thermal plants, each with a capacity of 250 MW (for a total of 750 MW). Stage Two is currently undergoing repowering which involves the conversion of its three steam thermal plants into two combined cycle gas turbine units, each with a capacity of 430 MW (for a total of 860 MW). The gas turbines are supplied by Mitsubishi Heavy Industries. The repowering project is scheduled for completion in 2012.

Stage Three, which was completed in 1983, comprises two steam thermal plants, each with a capacity of 250 MW. The turbines are from Hitachi.

In the 1990s, Senoko Energy started experimenting with the use of gas turbines using natural gas. In 1992, Senoko Energy became the first power generation company to import clean natural gas for power generation.

After three years of evaluating the viability and reliability of gas turbines, Senoko Energy became the first power generation company to adopt the combined cycle concept. The combined cycle plants CCP 1 and 2 were completed in 1996. Each of the plants uses Siemens turbines, and has a capacity of 425 MW.

The combined cycle plants CCP 3 to 5 became fully operational in 2004, and involved the repowering of the former Stage One oil-fired steam thermal plant. Each of the three combined cycle plants, with Alstom turbines, has a capacity of 365 MW.



CCP 1 & 2 overlooking the Johor Straits with Johor Bahru at a distance. CCP 1 & 2 was Senoko Energy's and Singapore's first repowering project and involved the conversion of four open cycle gas turbines into two blocks of combined cycle gas turbines.



Chimney stacks of Stage 3 (middle) and CCP 3 - 5 (right). The repowering of CCP 3 - 5 involves the conversion of the old Stage 1 oil-fired steam units into combined cycle gas turbine units. The picture also shows that the Stage 2 chimney had already been dismantled as part of the Stage 2 repowering project which is now nearing completion.



The 701F4 gas turbine at the Takasago Machinery Works of Mitsubishi Heavy Industries (MHI). The gas turbine, the most advanced and most efficient F-class turbine from MHI, is part of Senoko Energy's Stage Two repowering programme.

PPGT which is located at Pasir Panjang Power Station comprises two oil-fired gas turbine generators, using Siemens gas turbines, one of which is still operational and has a capacity of 105 MW.

### Energy efficiency and environmental impact

Since 2000, Senoko Energy has been converting its steam plants to combined cycle power plants which has an efficiency of 40% to 50%. The cost savings are passed on to consumers and industries.

'Senoko Energy embraces a different kind of repowering with combined cycle power plants. We reuse much of our existing equipment. Also, by building within the existing facility, we have reduced the footprint required for a power generation plant. As a result, we have a commercially viable power generation system', said Mr Kwong.

The replacement of steam generating plant with a combined cycle power plant on the same footprint, without additional land area, is an engineering feat, because an 860 MW plant has to be accommodated on an area where a 750 MW plant is sited.

An important feature of using the combined cycle power plant is the reduction in the carbon dioxide emissions by 2.5 million tons annually. The new repowering plant contributes to a further reduction of 1 million tons of carbon dioxide emissions.

'Totally, the 3.5 million tons is a significant contribution towards carbon dioxide reduction by a single company', said Mr Kwong.

In the past, CO<sub>2</sub> emitted / KWh of power produced by the company was 0.71 Kg CO<sub>2</sub> /KWh. With the installation of the combined cycle power plants, this has been reduced to 0.43 Kg CO<sub>2</sub> /KWh which is below the average for the Singapore grid, of 0.45 Kg CO<sub>2</sub> /KWh. With the new repowering (which will result in a further reduction of 1 million tons of CO<sub>2</sub> per annum) this figure will be lowered to 0.36 Kg CO<sub>2</sub> /KWh.

### Commitment of shareholders

Senoko Energy's repowering programme was announced around the time of the onset of the global financial crisis in 2008. The company's shareholders decided to go ahead with the capital-intensive exercise, because they believe that Singapore has a great future and it was the right time to give the republic vote of confidence. Also, they are sure that Singapore's electricity market will continue to embrace new power generation concepts.

'Stage Two repowering actually gave a lot of impetus to the Singapore's electricity market', said Mr Kwong.

### Water efficiency

By replacing steam turbines with combined cycle power plants, the water requirement for power generation is reduced.



Operations staff working in front of a console in the control room where most of the operation of the plant takes place.





Furthermore, Senoko Energy has built a seawater desalination plant to supplement the NEWater the company is already using.

'We desalinate water and use it for boiler feed water for the steam plant or for even the heat recovery steam generator', said Er. Eu.

'In the past, potable water was used for boiler feed water. There was therefore the need to remove the minerals in the potable water to make it to boiler feed quality. By using NEWater and desalinated water, potable water is reduced as it is now required only for use by the staff', he added.

Around one-third of the requirement of process water is met by desalinated water, complementing the use of NEWater which meets two-thirds of the requirement.

Senoko Energy is the first power generation company in Singapore to build a desalination plant.

### The Smart Grid

All over the world, different countries are developing different solutions for the application of the Smart Grid. In Singapore, the Energy Market Authority (EMA) is looking at what can be adapted to Singapore, when it starts the Smart Grid Pilot in 2013.

Senoko is one of the many market participants in this initiative, and is currently working with EMA on what can be adapted for a viable Smart Grid.

Looking at the energy consumption, the Smart Grid will benefit commercial and industrial customers more than residential customers.

'However, this will involve people willing to shift their loads from peak periods to off-peak periods, and also improving the efficiency of their operation, that is, using less KWh' said Er. Eu.

All images by Senoko Energy.



The Senoko Energy Electric Vehicle on the road, with Er. Eu and Mr Kwong.

## Senoko Energy Electric Vehicle

Senoko Energy recently purchased an i-MiEV (Mitsubishi Innovative Electric Vehicle), as part of EMA's Pilot Project to test out this greener mode of transport.

The i-MiEV uses a 16 kilowatt-hour lithium ion battery pack. Its 47 kW motor gives 63 horsepower and a high torque of 180 Nm (equivalent to a 2-litre car) for a maximum speed of about 130 km/h, with a cruising range of approximately 150 km.

### PERFORMANCE DATA

#### Good torque from standstill (due to motor)

A small size does not have to equal a small performance. The lightweight, highly efficient permanent magnet synchronous motor delivers strong and linear acceleration and surprising passing power with a maximum 180 Nm of torque which is equivalent to that for a two-litre vehicle. Due to its low centre of gravity, the i-MiEV has good handling performance.

The EV also has a feature, under various driving modes, to regenerate power while in motion, to charge the battery during braking or downhill driving. This helps to extend battery life and the distance covered by the EV.

#### Single charge cruising range

The EV has a cruising range of about 150 km. The Mode2/3 charge system can be used to charge the EV from an empty state to 80% charged in 30 mins, and fully charged in 6 hours. The Mode4 quick charge system can be used to fully charge the EV in 15-30 mins.

#### Zero drive-time CO<sub>2</sub> emissions

The i-MiEV is a zero-emissions vehicle (ZEV) which produces no CO<sub>2</sub> emissions while being driven. Even when the CO<sub>2</sub> gas emitted at power generating stations is taken into consideration, the i-MiEV generates approximately one-third of the CO<sub>2</sub> produced by the petrol 'i' minicar.

#### Driven 100% by electrical power

The i-MiEV is economical because it uses only electricity as its power source. Depending on the electricity rate structure, the running cost can be reduced further by off-peak charging of the battery if that rate is lower.

#### Charging station

There is a Mode3 Bosch Charging Station at the Senoko Power Station, capable of charging two EVs simultaneously as well as transmitting EV usage data remotely via 3G for analysis. The car parks at the power station are also EV-ready, with 16 amp power supply points to connect the OEM-supplied Mode2 cable for safe indoor charging. Bosch was appointed by EMA to install the charging infrastructure across Singapore for the EV Pilot Programme. There would be about 63 charging stations island-wide when the pilot infrastructure is fully rolled out.



## Interactive objectives and constraints between microgrid elements of the smart grid

It is inevitable that the visions for power systems will be based on the smart grid. On the other hand, the energy crisis enforces utilising renewable and clean energy through small-scale microgrids. Interactions of these two growing new technologies require development of more complicated control strategies. In other words, while each microgrid has to satisfy its own localised constraints and objectives, limitations and objectives enforced by the whole smart grid and/or microgrids require extended and more conservative constraints.

In the first part of this article, Fazel Farahmand, from Operation Technology Inc, California, USA, provides a comprehensive review of microgrids and smart grid

control strategies. The review covers clean energy stability analysis, generation control, generation forecasting, load forecasting, power management, load management, interchange analysis of microgrids, multi-objective and multi-constraint optimisation, as well as load shedding on localised and global grids. Finally, combinations of some of the discussed different control strategies are provided through the application of an industrial tool on a real grid example.

### INTRODUCTION

According to the United States Department of Energy, today's power system is 99.97% reliable. But just the 0.03% unreliability costs US\$ 150 billion a year. It is also a fact that if grids were just 5% more efficient, energy saving would be enough to permanently reduce fuel and greenhouse gas emissions. That is just enough to emphasise that increasing attention to reliability, efficiency, environmental issues, and global competition has



Figure 1: Platform of typical power system management.

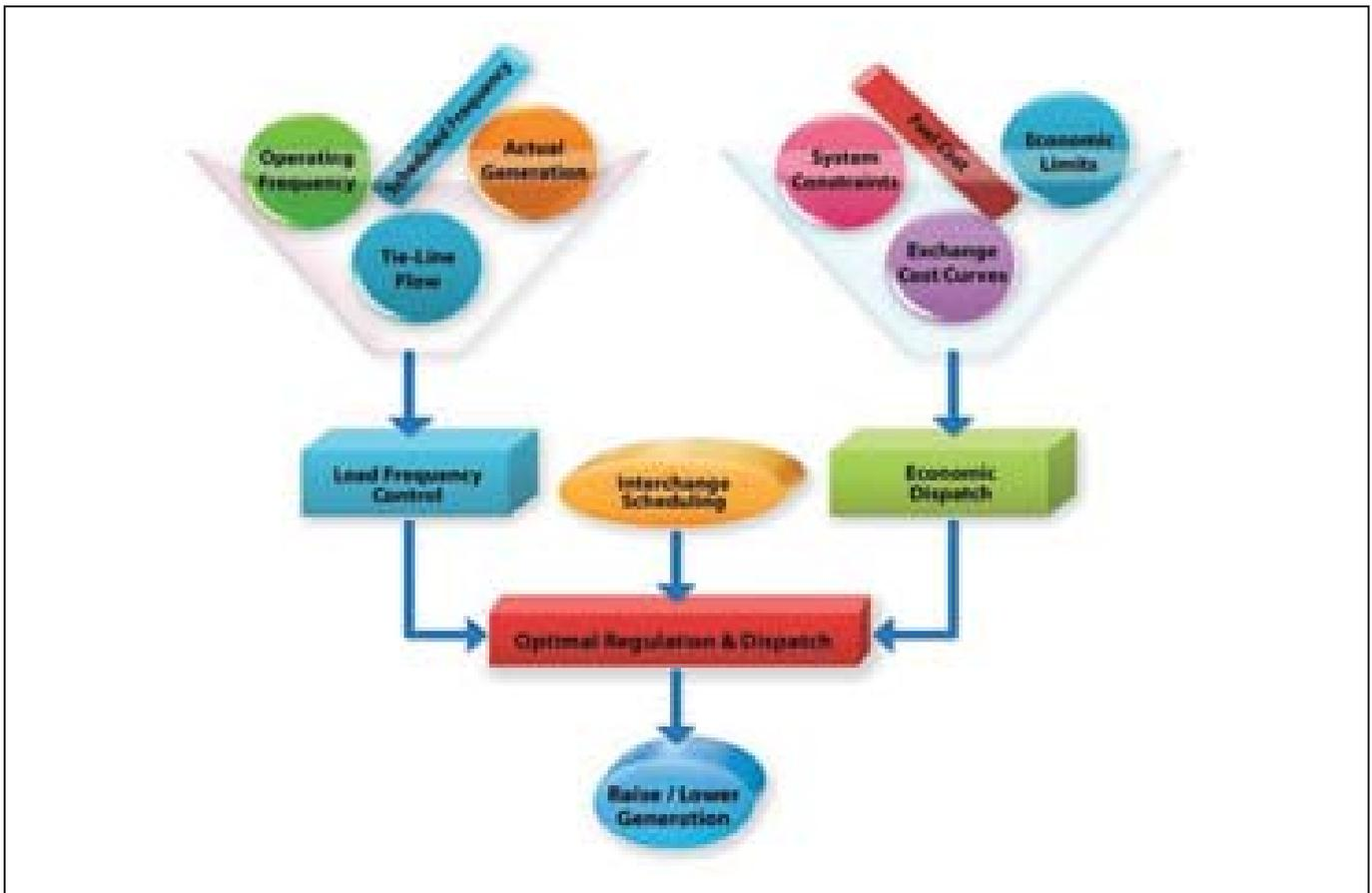
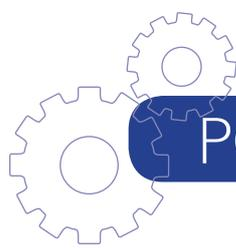

Figure 2: Flowchart for a smart energy management system.

pushed forward all nations to smarter power systems. To take the first steps in this way, every element of the power grid should act smart and be efficient. That is the backbone of smart grid's development, where its newly developed microgrid elements can be a zero-net energy commercial building, Plug-in Hybrid Electric Vehicles (PHEV), a wind farm, or solar panels.

### SMART GRID CONTROL STRATEGIES

The aim of this article is to develop an insight into the structure of micro grids and smart grids. Figure 1 provides major control strategies through an enterprise solution for power systems.

#### Energy Management System

While power generation is distributed all across the grid, there are growing energy demands and increasing climate factors that have raised more interest in clean energy resources. These changes in the structure of the power industry have brought new challenges and concerns which require a trustable and smart energy dispatching tool. Any suggested energy management tool should be responsive to random or sudden demand variations. Compared to centralised control, distributed smart dispatching has to be network oriented. Figure 2 shows a flowchart that structures energy management. Major grid requirements can be categorised but not limited to Interchange Transaction Scheduling, Automatic Generation Control, and Economic Dispatching.

#### Economic Dispatching

Economic Dispatching (ED) which, these days, is known as Smart Dispatching by smart grid users and also known as micro-dispatching by microgrid providers, has the key role in smart grids. The major point of having ED is to maximise economical power generation and distribution benefits while maintaining customer control. In other words, energy providers must match demand and dispatch generation in the most economical way while system and customers' requirements are considered. Wide and interactive optimisation objectives might need to be satisfied while system requirements and constraints must be taken into account (Figure 3).

Objectives: The ED objective function consists of all or some of the following items:

- Minimise fuel costs.
- Minimise transaction costs.
- Minimise power (Active/Reactive) losses.
- Minimise control movements/adjustments.
- Minimise differences in system voltages.
- Optimise voltage/line flow security indexes.
- Adaptive solution and robust algorithms.
- Minimise maintenance costs.
- Minimise start-up costs.

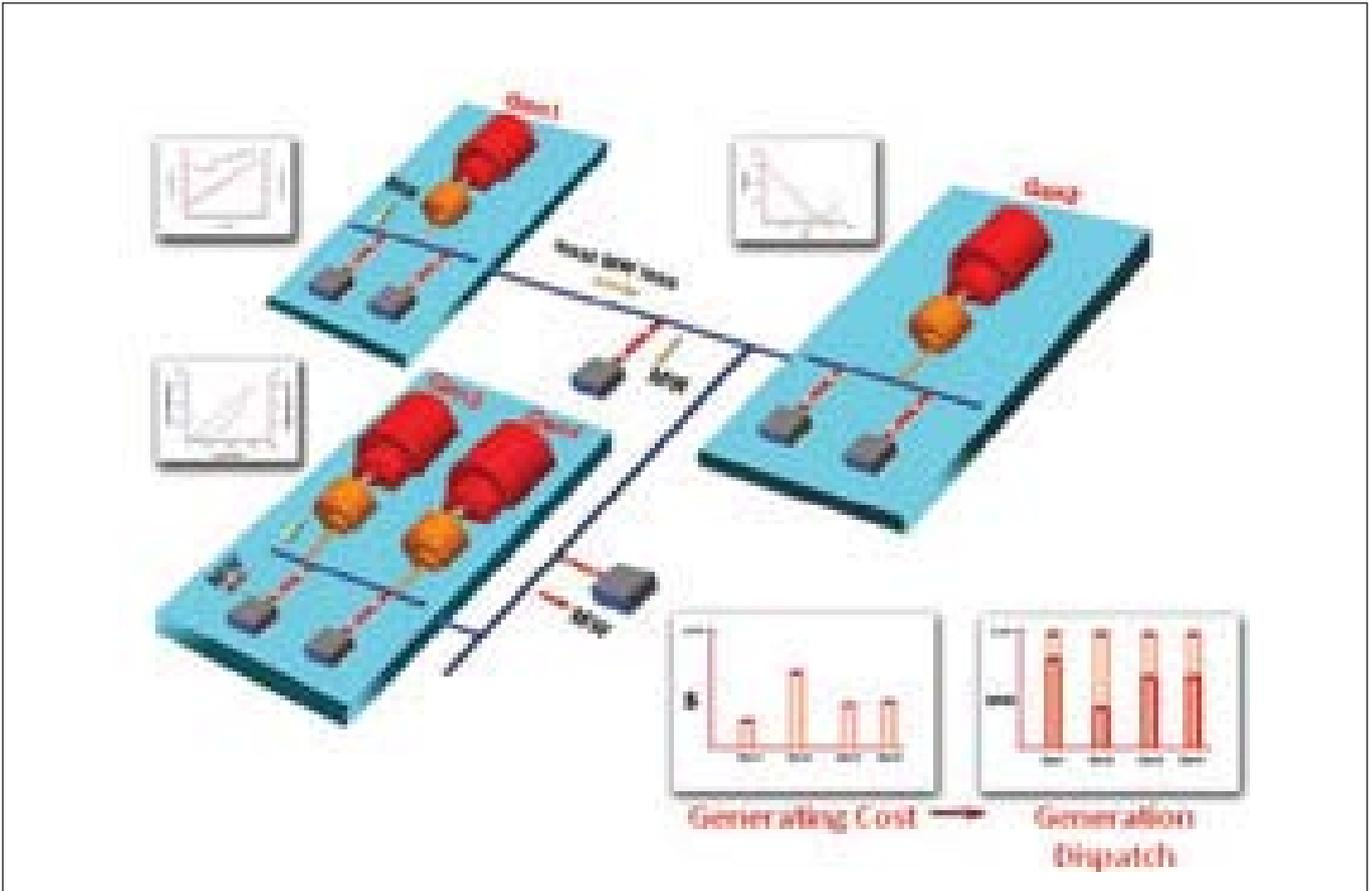

Figure 3: ED for minimisation of fuel cost for three generation plants operated with different fuel costs and efficiency curves.

Constraints: All or some of following constraints are enforced in ED calculations:

- Generation (MW, MVAR, AVR, PF).
- Bus voltage.
- Interchange Transaction Schedules.
- Branch flow (MW, MVAR, AMP, MVA):
  - Transformer
  - Cable
  - Line
  - Reactor
  - Impedance

### Automatic Generation Control

For a stable grid, systems must assure balance between constantly varying load and generation. While the microgrid's interchange commitment to the utility has to be satisfied, the frequency error at the interconnection has to be taken into account for the Area Control Error (ACE) calculation. Ideally, ACE should remain zero at all times. Load variations tend to have non-zero ACE. Positive ACE requires decreasing generation while negative ACE enforces increasing generation. Normally momentary generation/load imbalances of each control area results in controlling error diversity. In such cases, Area Control Error (ACE) Diversity Interchange (ADI) offers a means of reducing this control burden without sacrificing any participant in a group.

$$ACE = (NI_A - NI_S) - 10\beta_f(F_A - F_S) + I_{ME} \pm \beta_t \Delta t$$

Where,

$NI_A$  is Actual Net Interchange (MW)

$NI_S$  is scheduled Net Interchange (MW)

$\beta_f$  is Control area's frequency bias setting (MW/0.1 Hz)

$F_A$  is actual system frequency (Hz)

$F_S$  is scheduled system frequency (60.0 Hz in USA)

$I_{ME}$  is manually entered amount to compensate for known equipment error (MW)

$\beta_t$  is time error bias in MW/Sec of time error and is also considered negative

$\Delta t$  is time error in seconds, negative for slow and positive for fast.

### Interchange Transaction Scheduling

For a smart grid environment, the goal is to decrease the amount of uncertainties and to operate the system with the highest confidence. Therefore, interchange schedules are enforced to be agreed to by connected microgrids. Interchange Transaction Scheduling (ITS) provides the capability to schedule energy transfer from one control area to another while considering wheeling, ancillary services scheduling, and financial tracking of energy transactions. As can be seen from Figure 4, dedicated for electricity power exchange and scheduling, ITS incorporates energy scheduling, transaction management, and energy cost analysis and reporting.

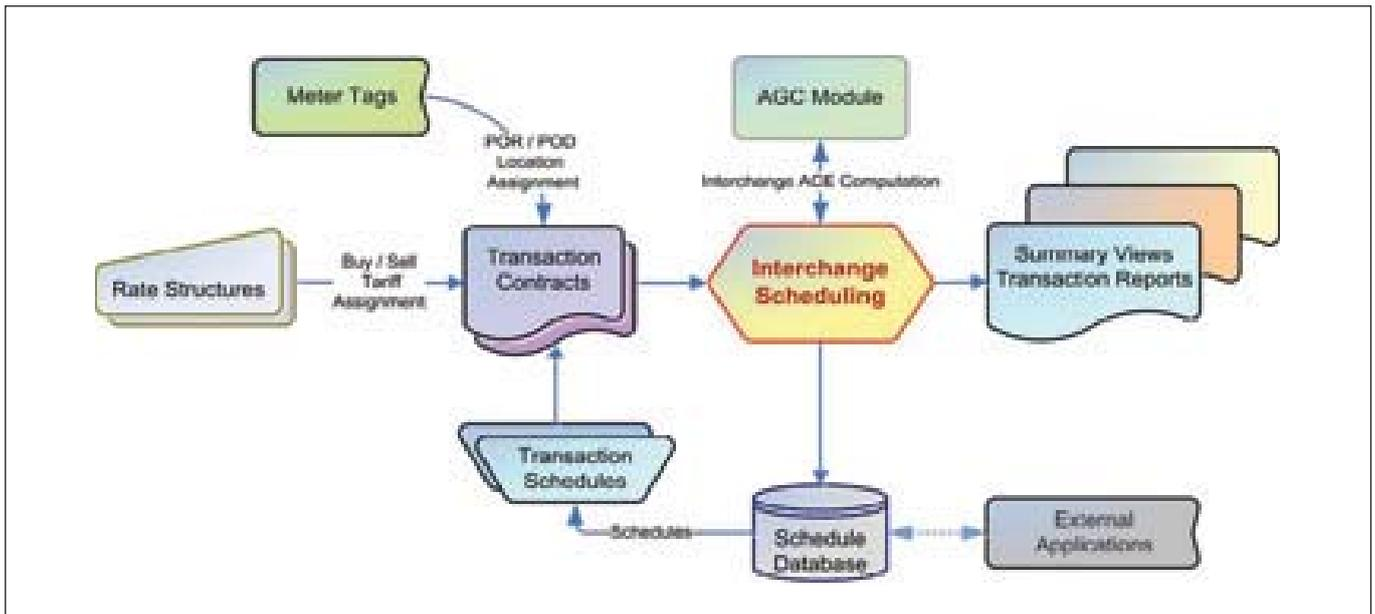

Figure 4: Schedules are stored in a database while generation is under the effect of AGC modules and controlled based on meter readings.

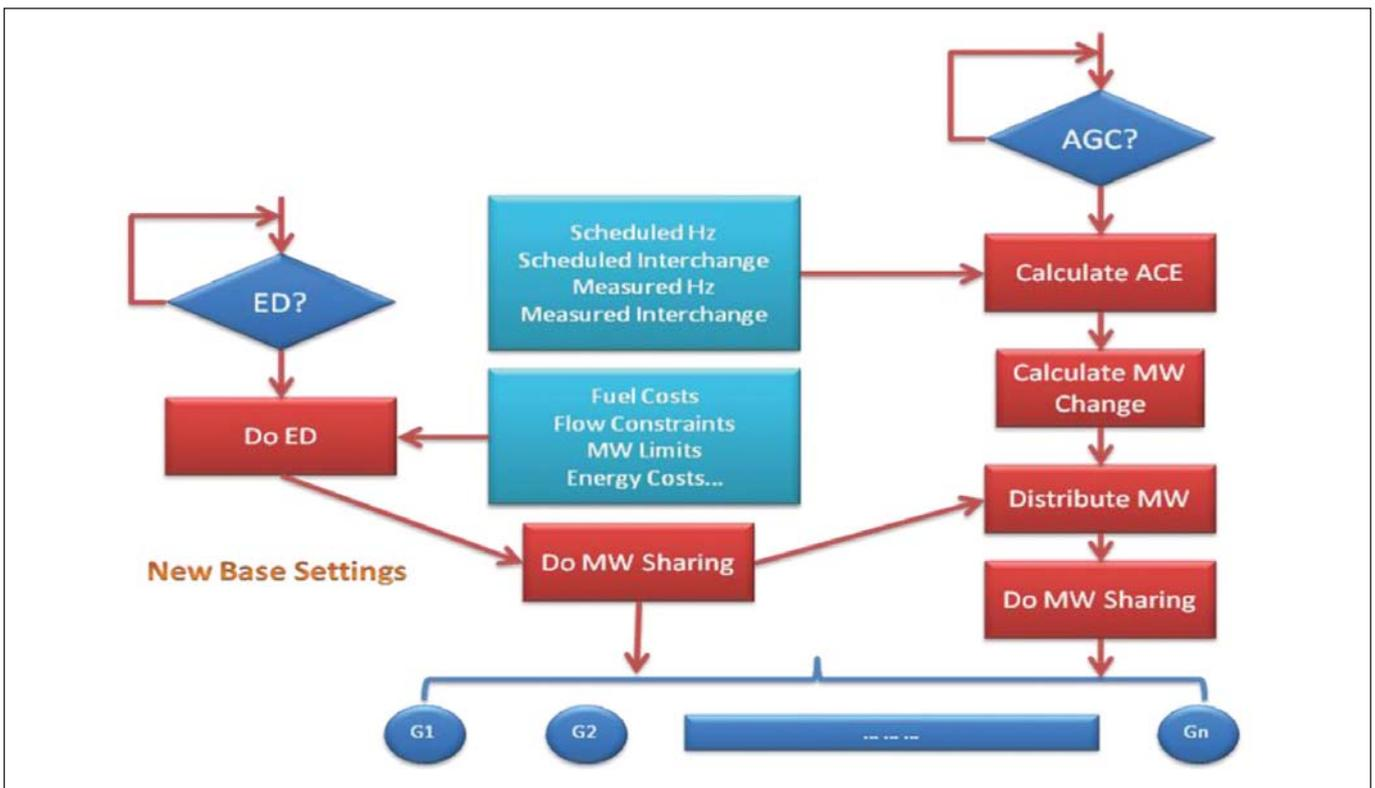

Figure 5: Control of generators under interaction of the system's constraints enforced by ED and adjustments imposed by AGC.

When all the grid's constraints and the system's objectives are defined, AGC, ED, and ITS would interact to adjust total generation of generators (Figure 5). Each of these generators can be a microgrid subsystem distributed nationwide.

### Intelligent Load Management

In order to distribute generation smoothly over time, different tariffs are enforced to users. That normally includes higher rates at hours of higher demand. That is because most of the

time peaker plants will sit idle, while their cost stays almost the same to maintain or operate. Smart grid is not limited only to generation and transmission. Smart users distribute their load consumption over time to have lower power peak and least cost impact from tariffs enforced by the energy seller. Proper distribution of consumption over time decreases the peak problem and consequently decreases the required size of the spinning reserve.

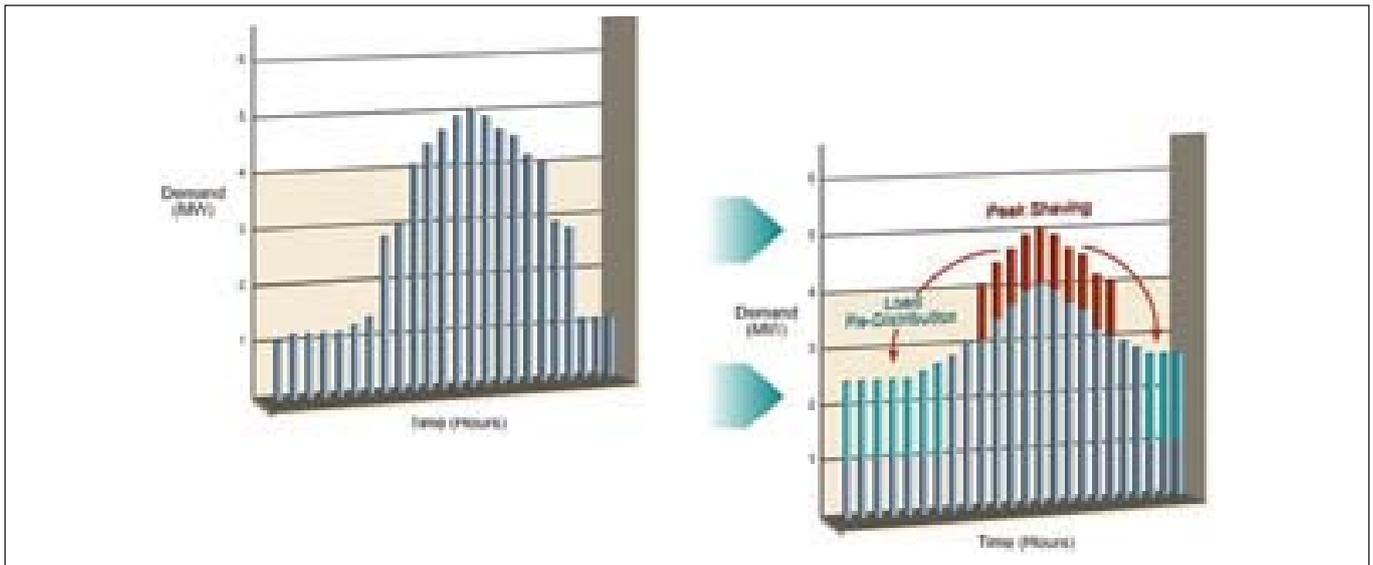

Figure 6: Demand distribution over time for lower consumption peak.

### Load shedding

By definition, load shedding is the amount of load that ideally must be shed from the grid in order to maintain stability and performance of the remaining active parts of the grid. Considering the fact that power systems normally operate in stable condition, load shedding is enforced in response to a system disturbance like switching errors, lightning strikes, loss of generation, and faults that end up with a generation deficiency condition.

Mostly, in cases of lightning strikes or switching surges, a microsystem or a large portion of the smart grid might be isolated from the whole grid. An ideal load shedding scheme should be smart enough to act based on the latest system configuration. Actions must be independent for every isolated subsystem, and the action should be fast, correct, reliable and prioritised, based on minimal possible shedding in minimal electrical distance.

### Major load shedding methods

#### Breaker interlock scheme

The breaker interlock scheme is the simplest and fastest load shedding method to drop a constant amount of local loads in a microgrid based on a specific action (see Figure 7). For larger power systems, where a grid might be affected by another grid, this technique might not be enough or even applicable.

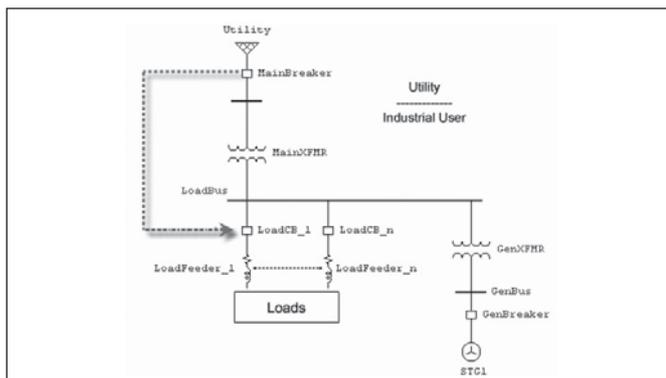

Figure 7: Breaker interlock load shedding scheme.

#### Under frequency relay (ANSI Device 81) scheme

One of the major effects of disturbance on a power system is frequency collapse or degradation. Frequency relays respond to this disturbance in a timely manner and shed loads. Frequency relays normally act in two stages. The first stage of action occurs right after a frequency drop is observed and the second stage occurs after a few cycles, if system frequency does not recover. Because of the objective nature of this method, its response time is very slow.

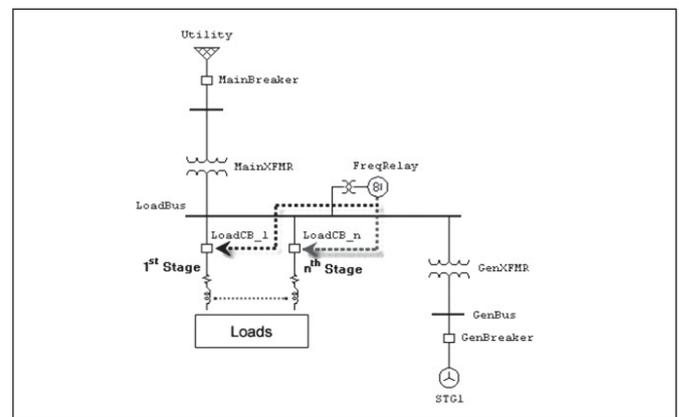

Figure 8: Under frequency load shedding scheme.

#### Programmable Logic Controller-based load shedding

Programmable Logic Controller (PLC)-based load shedding by far is a much more reliable and faster solution than the two previous discussed methods. Its action depends on the written PLC logic and can shed an optimal amount of load. However, the action of PLC is limited to the grid or microgrid controlled by that specific PLC and large smart grids. However, it still lacks system-wide operating conditions.

#### Stability-based load shedding

A load shedding algorithm based on voltage stability of the most sensitive bus is proposed. By controlling eigenvalues of the most

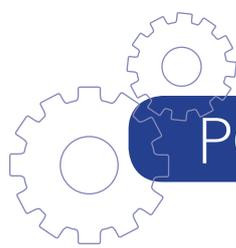

sensitive bus, this method recovers a disturbed system. Having correct and full knowledge of the whole grid's configuration and real-time ratings is a must for convergence and performance of this method.

### Intelligent load shedding

By having complete and accurate knowledge of a system, ETAP has proposed a new intelligent load shedding (ILS) technique. ILS is based on a user-defined logic for system disturbances called triggers and prioritised loads to be shed (Figure 9).

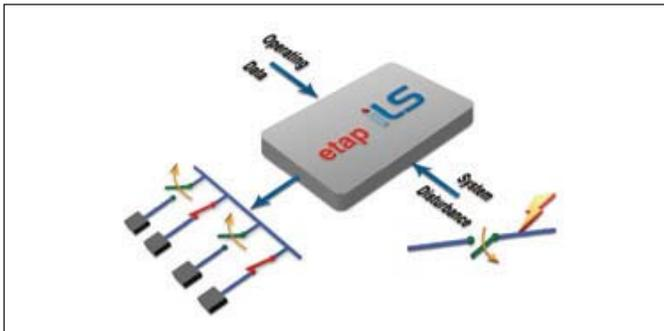

Figure 9: ETAP intelligent load shedding scheme.

An industrial comparison of discussed methods is illustrated in Figure 10, comparing two factors - total final load that is shed and load-shedding response time. The results demonstrate the advantage of ILS in being much smarter, faster, and more optimal for shedding load over conventional load shedding schemes.

### Minimise system maintenance

A key feature of ILS is the ability to update and customise the load shedding logic without performing any PLC re-programming. Changing load priorities, adding or removing loads from the system, and optimising logic are some examples of actions that do not require reprogramming of the PLC.

Trigger actions can end up in the islanding of a portion of the grid. In that case, ILS is intelligent enough to detect and act independently for the entire grid and every isolated microgrid. It is in comparison to PLC-based load shedding which cannot have an overlook on islanded systems.

### Load restoration

After successful removal of a major disturbance, the maximum possible load should be restored automatically. This action would minimise the duration of the outage while maintaining fault isolation without exceeding the capacities of alternate power sources and routes. In order to achieve this goal, loads at different subsystems are restored step by step or in one action.

The main criterion to run load restoration is the satisfaction of the grid's robust stability. This confidence is obtained by running different studies, eg load flow analysis, transient stability analysis, or eigenvalue analysis, of the whole grid prior to the load acceptance at any microgrid or substation. The restoration qualification feature evaluates the ability to restore loads by monitoring the system's essential parameters.

## ESTIMATION AND FORECASTING

While measurement and detection was a promising science a half century ago, estimation and prediction is tomorrow's demand. Apart from forecasting of the amount of power that will be generated, forecasting results can be used for plant sizing, ED, and operational purposes.

### Load forecasting

Utilisation of Advanced Metering Infrastructure techniques into smart grids has helped to accurately forecast loads in real-time. This information enables visibility of power consumption and increases the degree of control of the generation. This makes the load forecasting an ideal tool for industrial users as well as

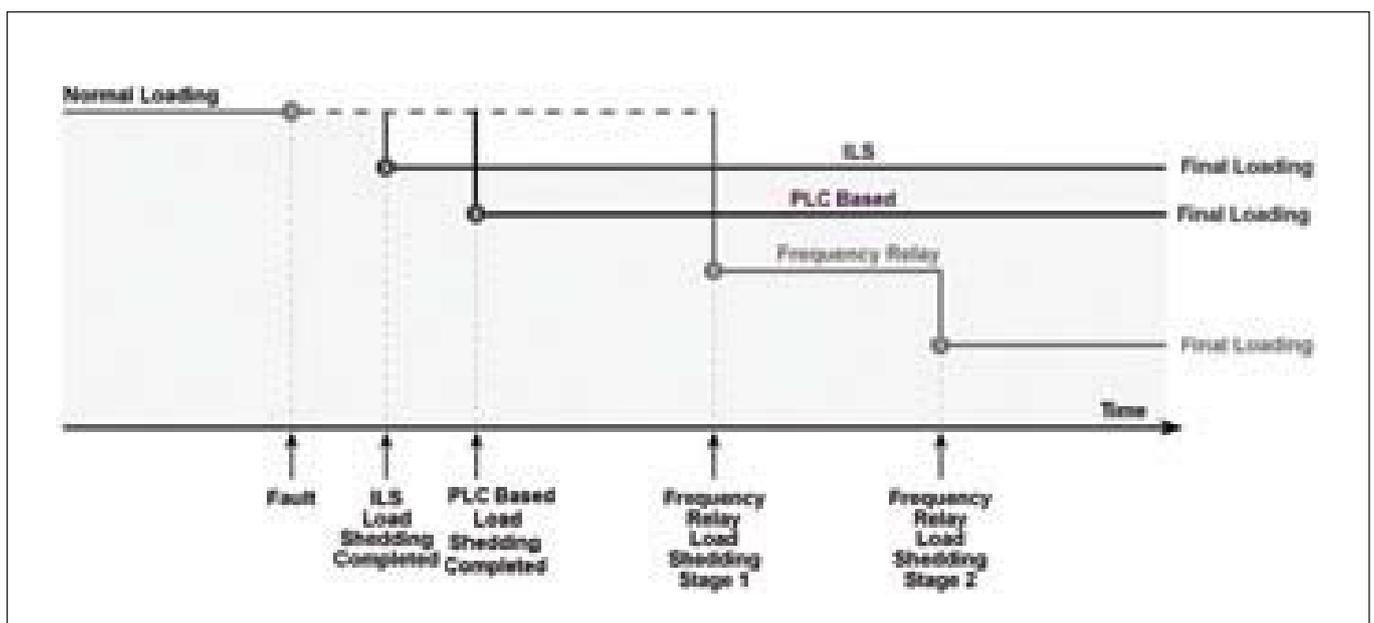

Figure 10: Comparison of ILS versus other conventional load shedding techniques.

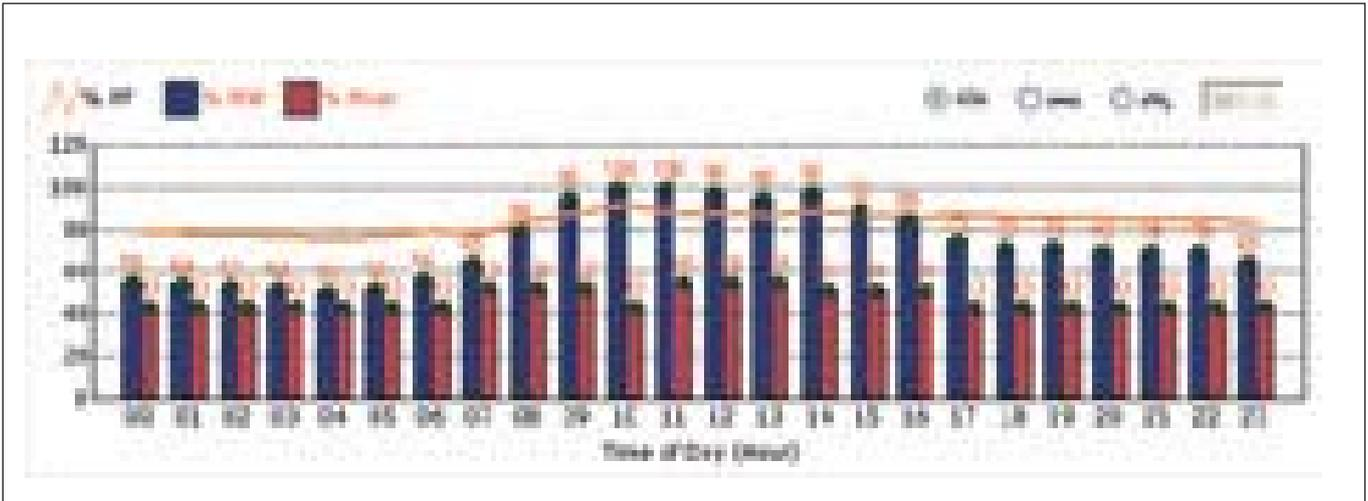

Figure 11: Estimated pattern of load at a meter at a specific location of the grid.

utilities to reliably and accurately forecast future loading in the system. A good forecast has a direct and significant impact on costly generating unit startups and shutdowns, energy purchases, managing system demand, and scheduling system upgrades based on predicted load growth. A great number of techniques like statistical methods (Figure 11), regression methods, or time series analysis, have been introduced for short-term load forecasting. The impact of new PHEV loads onto the grid is still being researched.

### Generation forecasting

Many factors from generation to distribution and consumption should be considered, to have a reliable forecast of power generation. As was discussed, load forecasting was one of the major tools developed at the user level. Utilisation of renewable energies like wind and solar impose additional variables that must be counted. For example, depending on the location of the wind farm, means of generation, skewness, coefficient of variation and kurtosis, the daily generation would change.

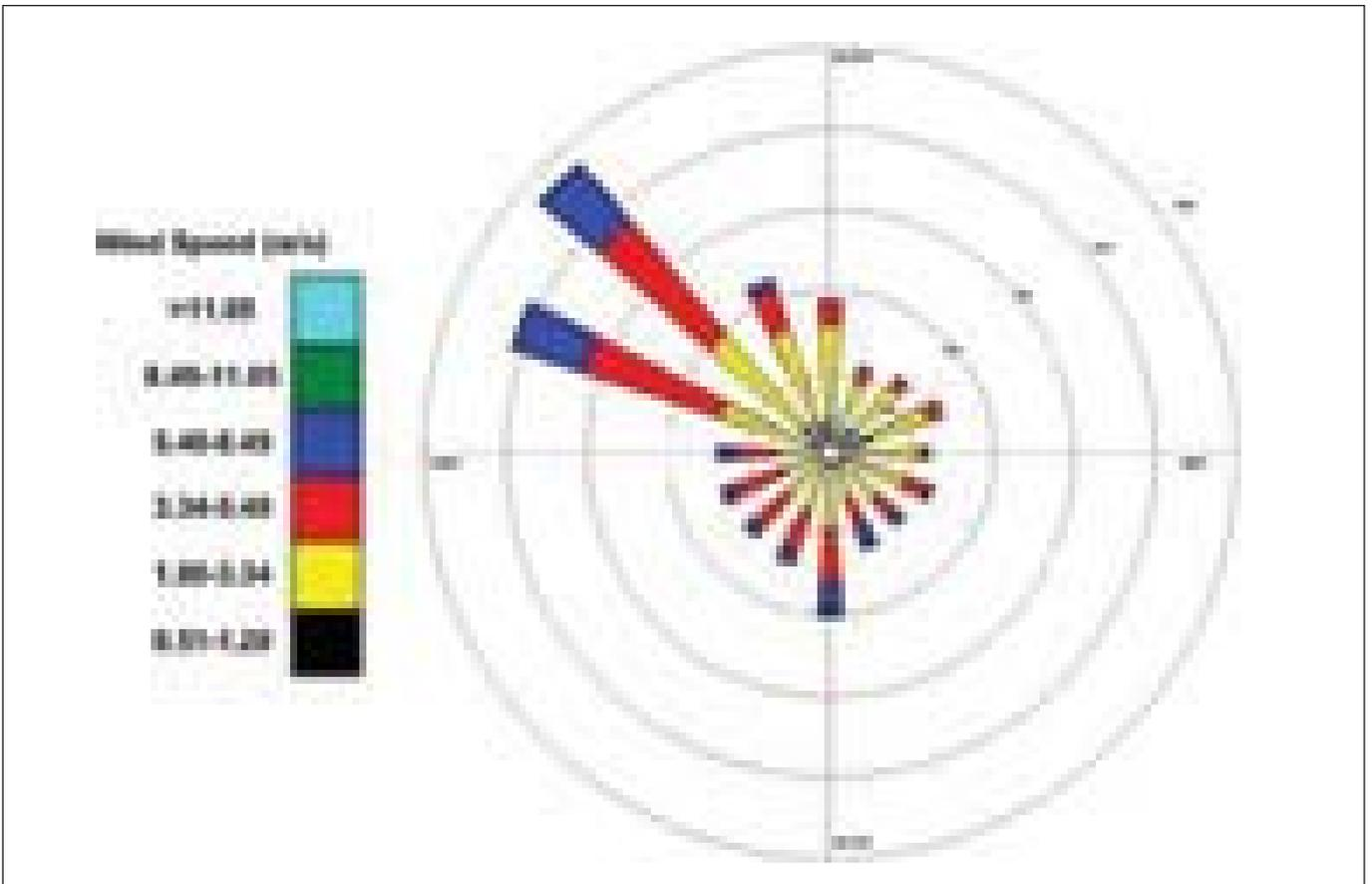
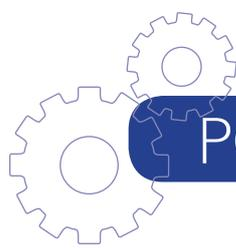

Figure 12: Wind rose which represents probability of direction and speed of the wind at a specific location of the grid.





There are two different approaches towards wind forecasting. Either future atmospheric variables are predicted and used toward calculations or statistical environmental data at a specific location is used to forecast generation. Figure 12 shows one of the most commonly used statistical patterns, which is utilised for wind forecasting. Already developed and in use in Germany, factors of level, minimum, average, peak, and even spurts of the wind energy are estimated.

Interestingly, winds are caused by differential heating of the earth's surface by the sun. This makes wind forecasting methods applicable to solar forecasting. That is why many forecasting service providers apply wind forecasting methods to solar generation forecasting. This fact makes wind generation and solar generation correlated phenomena. Another approach to energy forecasting is error forecasting which is used to determine how new clean sources of generation will fit into the market models.

### State and load estimation

Techniques of state estimation date back to the early 1970s. The basic problem of state estimation techniques was that the power system model should be known exactly. There is a fundamental



Figure 13: State and load estimation uses a limited number of meter readings.

difference between traditional state estimation and distribution state estimation required for the smart grid.

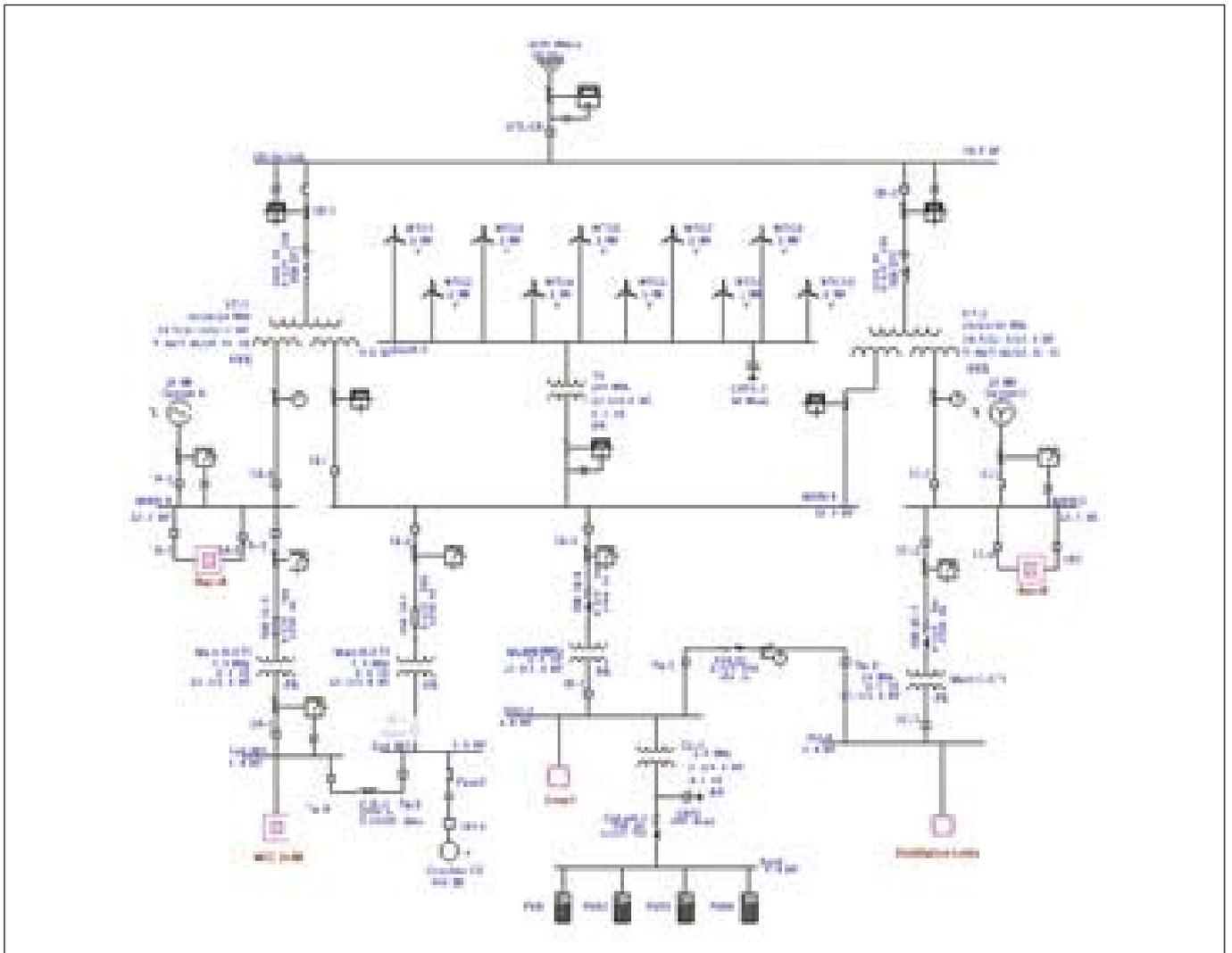

Figure 14: An example of a 21-bus system with connected wind farms and solar panels.

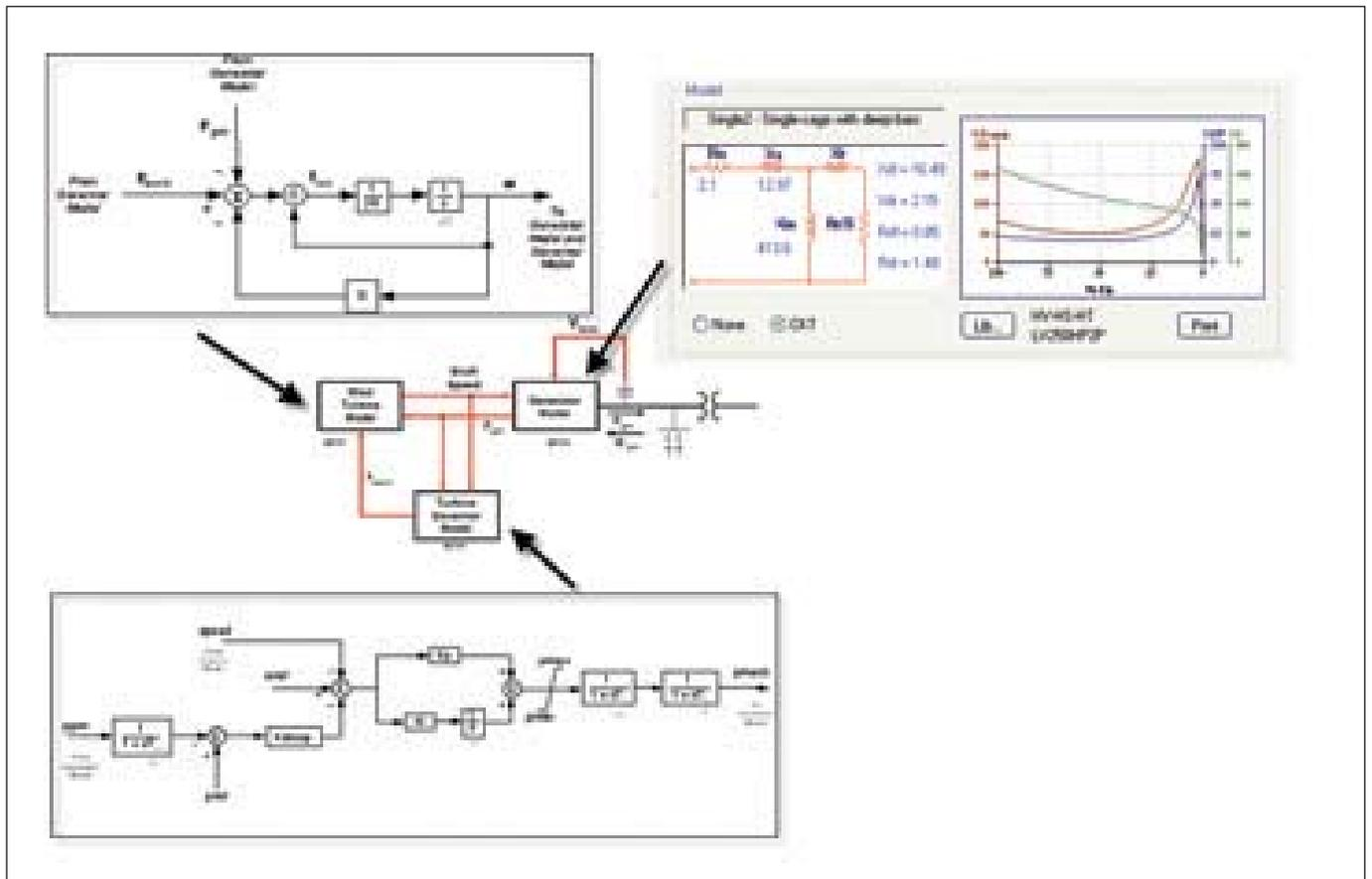

Figure 15: Schematic of an individual WECC-Type 1 wind turbine model in ETAP.

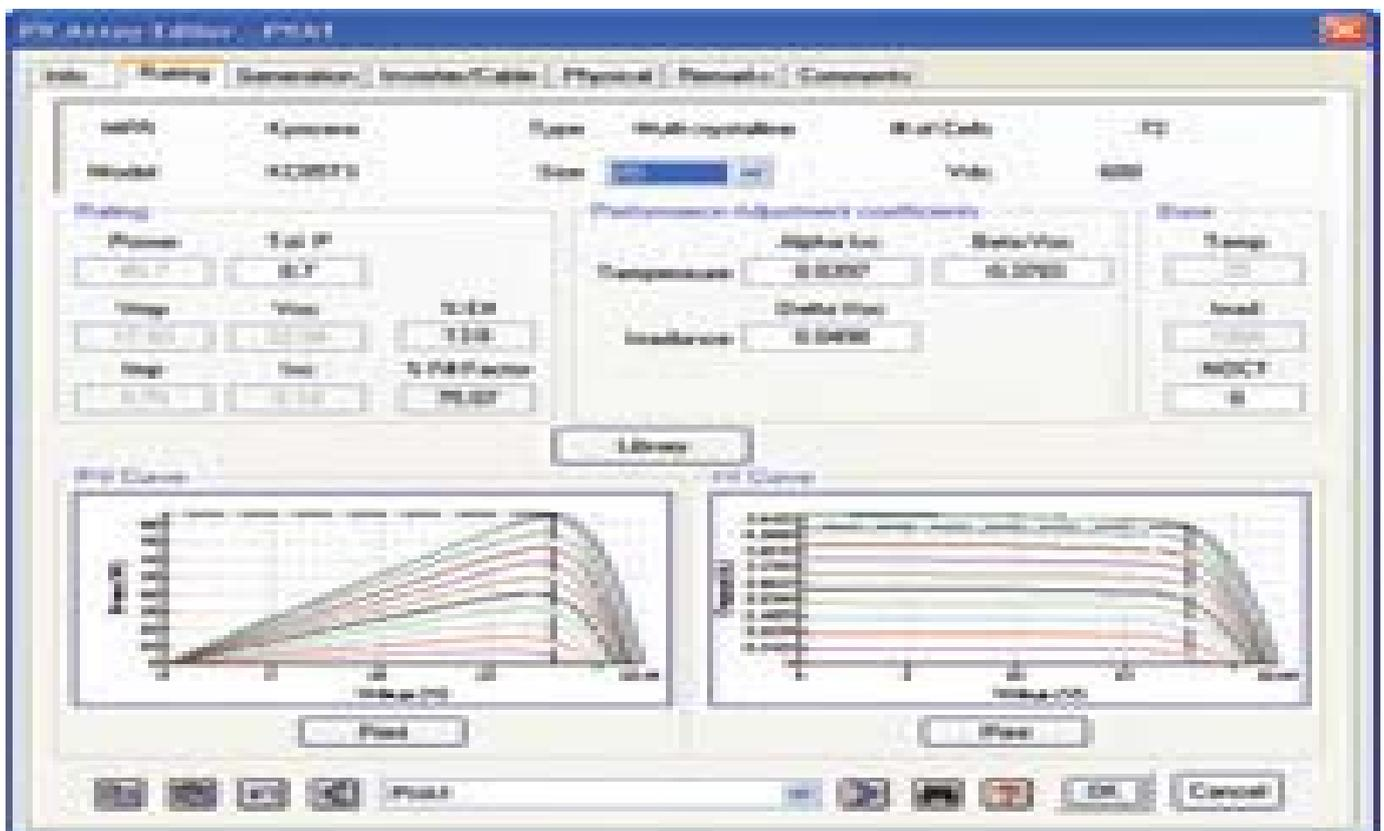
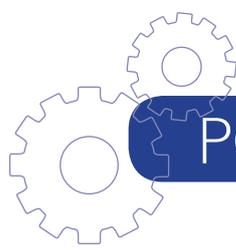

Figure 16: An example of a PV array editor.



First, while topology of transmission systems was analysed as a whole, a smart grid has many independent substations and short or low impedance branches which raise numerical problems. Second, a smart grid has non-observable subsystems with many unmeasured load points. Also, rather than having a system with a few hundred or the maximum of a couple of thousand buses, smart grids range from 10,000 to 100,000 nodes. Last but not least, rather than a balanced power system, grids are normally unbalanced. In addition, there is also a good chance of having faulty meters, bad data, or measurement error, at different points by the grid. These issues have brought forward the idea of developing state and load estimation for smart grid analysis, rather than just having state estimation.

## EXAMPLE

An example of providing comprehensive multi-objective solutions to a system is shown in Figure 14. The example contains a power system with 21 buses, connected to a power grid, two synchronous generators, 10 WECC type one wind turbine generators (details are shown in Figure 15), four PV arrays (Figure 16), 10 two-winding transformers, 2 three-winding transformers, 30 CTs, 20 PTs, 12 cables, two capacitors, 43 HV circuit breakers, two composite motors, four inverters, 32 different kinds of meters (multimeter, ammeter, and voltmeter), with eight synchronous motors in different sizes and six lumped loads. This power system model was designed in ETAP 11 power system analysis and management software.

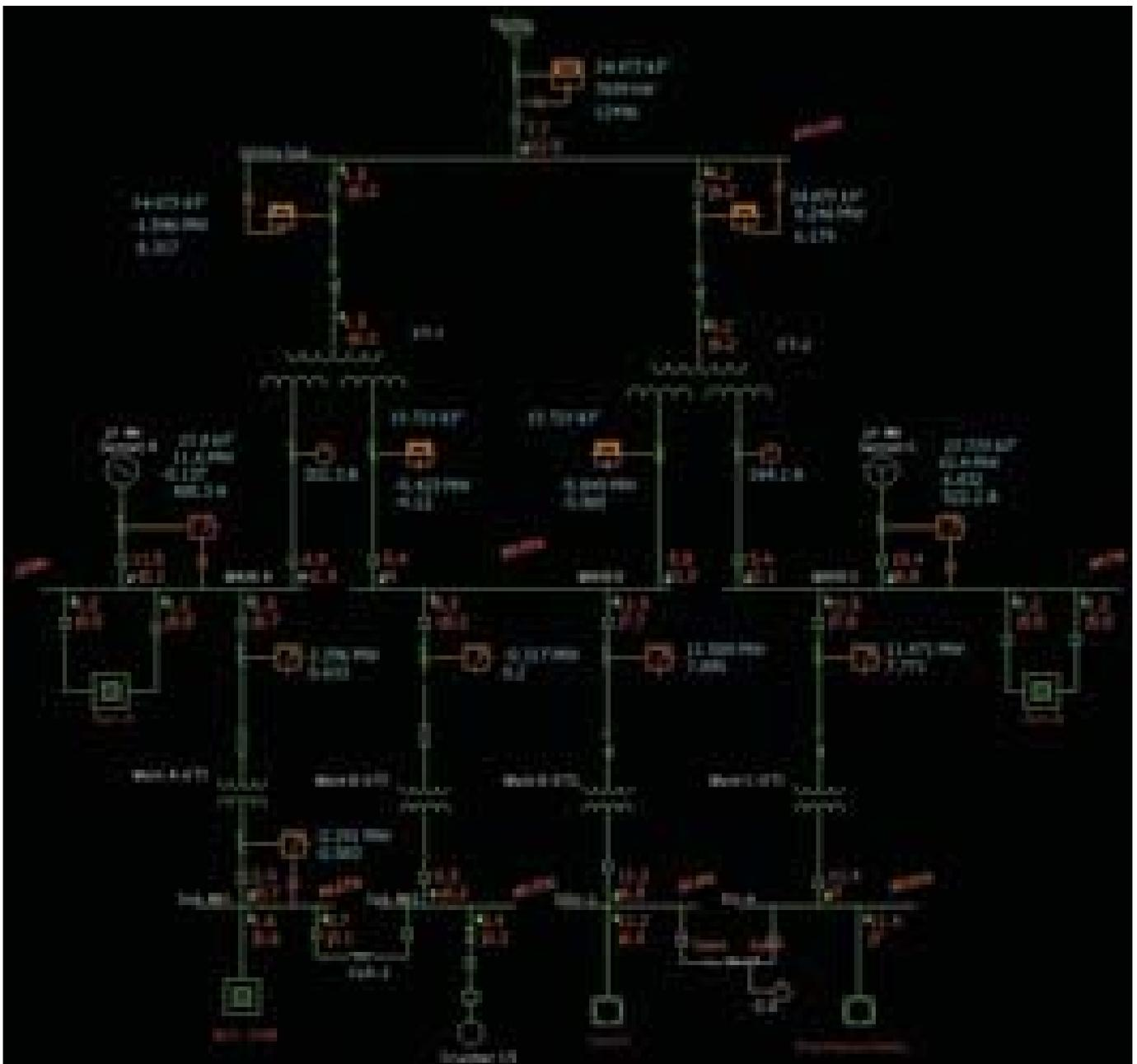

Figure 17: The smart grid utilised with SCADA data, SLE values, and running different real time modules in the background.

# POWER GENERATION



For the sake of simplicity in displaying of the one line diagram, ETAP provides the ability to design or put a portion of the model inside a composite network.

ETAP simulation software communicates with OPC servers to bring data from practically any provider of standard networking protocol or software platform, and display values as a monitoring tool. As can be seen in Figure 17, light blue values correspond to real-time data.

At the same time, ETAP communicates with a Microsoft SQL Server to archive historical data, schedules and rates. State and load estimation is running in real-time on this model and its calculated values are shown in red. For this example, power management is set to require minimal real power loss for economic dispatching, while AGC is set to have MW sharing for all generators (Figure 18).

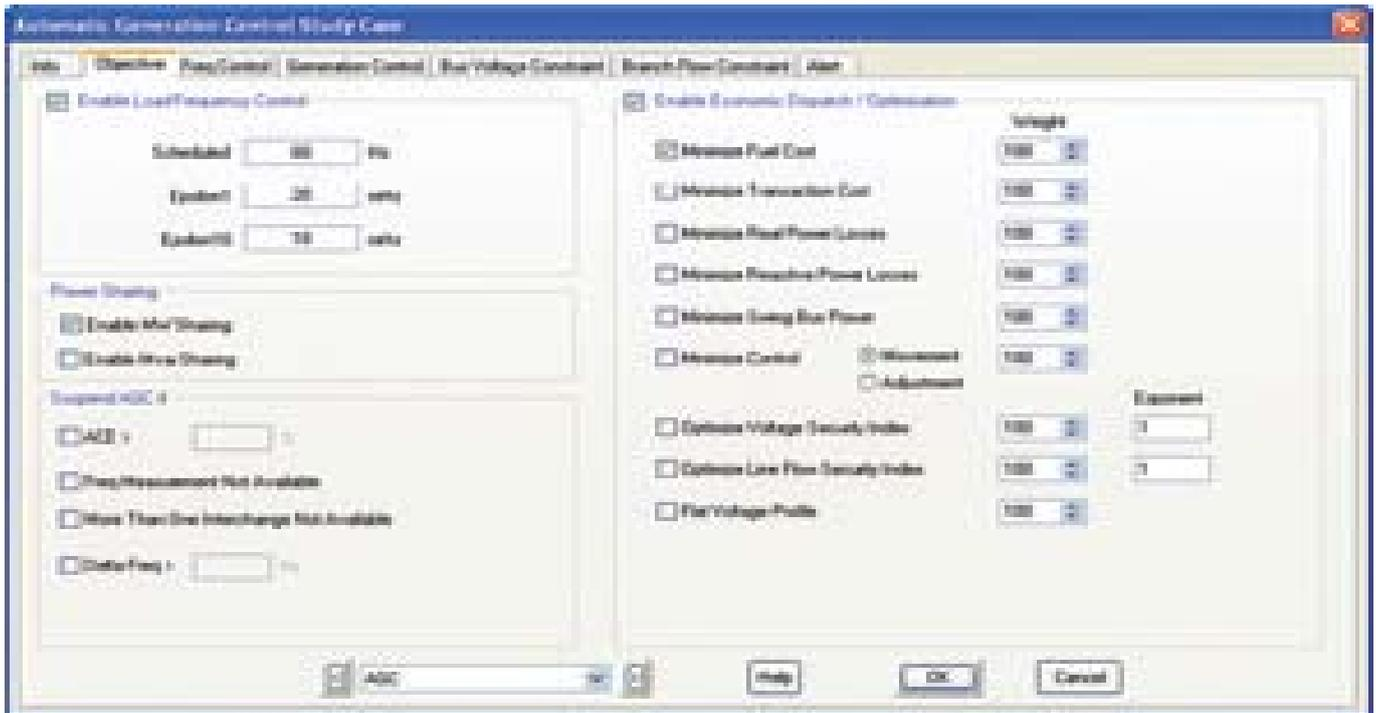

Figure 18: AGC parameters and ED objectives and constraints.

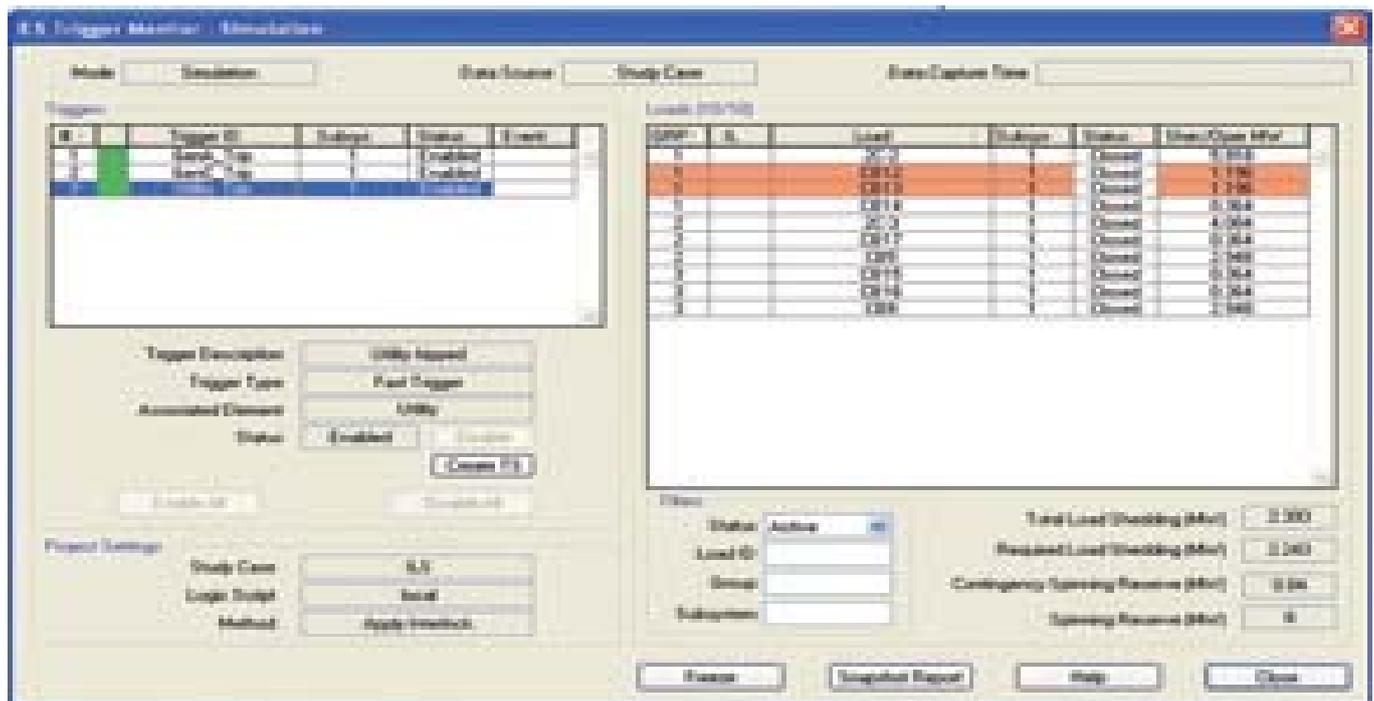

Figure 19: Load shedding results in case of tripping a generator or utility.

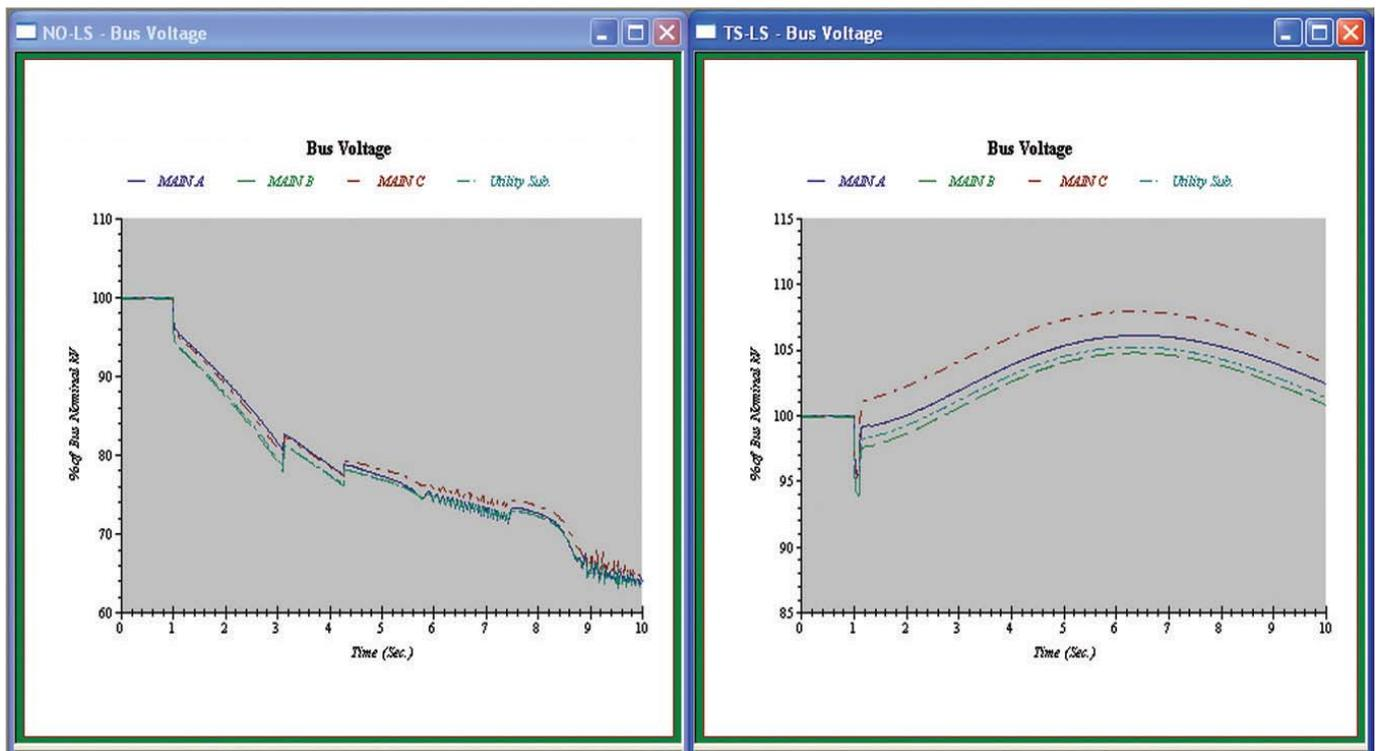
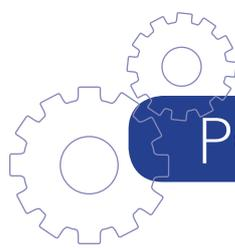

Figure 20: The picture on left shows the bus voltage of major buses without load shedding. The picture on right shows the grid response in the presence of ILS.

In addition to the above-mentioned control strategies, if any trigger action (eg utility trip) happens, minimal load would be shed at the fastest experienced time. A schematic of the ILS editor is shown in Figure 19.

Transient stability analysis is also done to compare and validate two scenarios of trip without load shedding and trip with load shedding. In this case, as can be seen from Figure 20, ILS suggests tripping CBI2 and CBI3. In such a case for the supervised grid, ILS sheds load and the system maintains its stability. However, for an unsupervised system, the grid will gradually become unstable and the system eventually runs into a full black out. In both cases, utility trip happens in a moment of one second. In the case of load shedding, the load is shed after 100 ms.

## CONCLUSION

The smart grid is characterised as a unified power system with all of its connected substations and generation resources. This makes power transmission and distribution a road with two avenues of information and electricity flows. Power flows have always been available and the development of new information technologies over the web and synchrophasors, have made data available over the globe.

The larger the size of the network, the more complicated are control strategies. This complication makes the control of the power system a chain of multivariable objectives, constraints, and interactive control strategies. It is essential that every facet and constraint in power systems be taken into account, so that a robust, reliable, and comprehensive solution is achieved.

As a solution to all commitments and obligations of power systems, ETAP goes beyond offering just one or two tools, to provide an enterprise solution to satisfy all interconnected and interacting requirements of every power grid. Its ability to provide load and generation estimation, real-time monitoring, forecasting, archiving, simulation, and optimisation, makes it the brain for the grid to act smart. Ultimately, a distributed area of power supply and decentralised generation coming from clean resources will be the future of power systems.

*(This article is based on a paper authored by Fazel Farahmand, Tanuj Khandelwal, JJ Dai, and Farrokh Shokoh, from Operation Technology Inc, California, USA, and presented by Fazel Farahmand at POWER-GEN Asia 2011.)*

*POWER-GEN Asia 2011 and Renewable Energy World Asia 2011 were held at the Kuala Lumpur Convention Centre, Kuala Lumpur, Malaysia, from 27 to 29 September 2011.*

*POWER-GEN Asia is the region's premier conference and exhibition for the power generation and transmission and distribution industries.*

*Renewable Energy World Asia is dedicated to the rapidly developing renewable and sustainable energy sector.*

*Both events are organised by PennWell Corporation).*

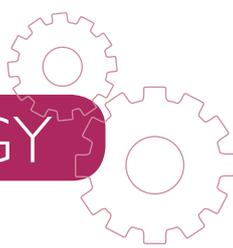

## Panasonic affirms commitment to solar technology

The successful acquisition of SANYO (which became a wholly-owned subsidiary in April 2011) has enabled Panasonic to become a major player in the area of photovoltaics and further strengthen its green commitment and activities.

### BACKGROUND

Based in Osaka, Japan, Panasonic Corporation (Panasonic) is a worldwide leader in the development and manufacture of a wide range of electronic products for consumer, business, and industrial needs.

Its subsidiary, Panasonic Asia Pacific has 48 manufacturing sites in seven countries in this region. Based in Singapore, Panasonic's Asia Pacific headquarters is a key hub for the company's global production activities. It also promotes environmental conservation initiatives and encourages the adoption of environment-friendly products through public eco-awareness campaigns designed for each country in the region.

On a broader scale, Panasonic Asia Pacific has specific goals to reduce its regional carbon footprint in support of the company's global eco initiatives, through the development and application of environment and energy solutions (for creating, storing, saving, and managing energy).

### SOLAR TECHNOLOGY

There are four factories in the Asia Pacific region producing solar technology products - Shimane SANYO Electric Co Ltd,

Shiga Factory, and Nishikinohama Factory, all in Japan; and the Kedah Factory of Panasonic Energy Malaysia, which is expected to start operations at the end of 2012.

Panasonic solar panels incorporate original Heterojunction Intrinsic Thin-layer (HIT) technology. The HIT cell structure of the solar panels consists of a mono-crystalline wafer, surrounded by ultra-thin amorphous silicon layers.

According to Panasonic, the HIT solar cell offers several advantages.

It is said to have a top level cell conversion efficiency of 21.6% when mass-produced. This means that more energy can be generated from the same amount of roof-top space.

Since the reduction in output from HIT solar cells at higher temperatures, is lower than that from regular crystalline silicon solar cells, it is predicted that approximately 44% more electricity will be generated per year for spaces installed with solar panels incorporating HIT cells.

Solar panels with HIT cells are said to be 44.4% lighter per installed watt, than average solar panels. This means they are more convenient to use.

### PRODUCTION BASE IN MALAYSIA

Panasonic Energy Malaysia recently commenced construction of a fully integrated solar products manufacturing centre in Malaysia, the first of its type in the world for the company. Located in Kulim Hi-Tech Park in Kedah, the new facility, which will make solar wafers, cells and modules, is expected to increase Panasonic's production capacity by 50%.

To be built at a cost of 45 billion yen, the new manufacturing base is expected to start operations by December 2012. It will enable integrated manufacturing of solar wafers, cells, and modules, based on Panasonic's HIT technology. The annual production capacity is estimated to be 300 MW.

With increasing environmental awareness globally and the introduction of subsidy systems as well as feed-in-tariff schemes in various countries, the solar market is predicted to grow further. Robust demand is expected particularly in the residential sector; the main target market for Panasonic HIT solar modules.

This new base will help Panasonic not only to increase solar module production and meet market demand, but also to strengthen cost competitiveness as a result of the integrated production of wafers, cells, and modules. Panasonic will sell its solar modules individually and also as a system with storage batteries and other devices.



*The Malaysian facility will produce solar wafers, cells, and modules.*

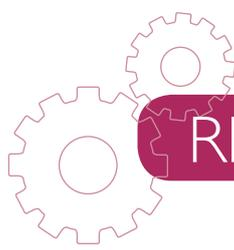

## MAJOR SOLAR INSTALLATIONS

Panasonic solar panels powered by HIT technology have been, and are being installed on projects in several countries in the region besides Japan, including Singapore, Malaysia, Indonesia, Philippines, Thailand, India, Australia, and New Zealand.

## SINGAPORE

### Ocean Financial Centre

Developed by Keppel Land Limited, the 43-storey Ocean Financial Centre received the Green Mark Platinum Award from Singapore's Building and Construction Authority. It is an office development strategically located at the intersection of the Raffles Place and Marina Bay precincts of Singapore's Central Business District.



Solar panels have been installed on the roof of Ocean Financial Centre, which is 245 m above the ground. Image by Keppel Land.

The solar system from Panasonic, comprising 366 panels, is installed on the roof which is 245 m above the ground. According to the company, this makes it the highest solar panel installation in Southeast Asia.

The whole solar system has a capacity of 75 kWp, and given the weather conditions in Singapore, the system is expected to generate 86 MW of energy in a year.

It is also said to be the largest solar system assembly for a commercial development in Singapore's Central Business District.

The solar system that has been installed at Ocean Financial Centre operates as a grid-tied installation where battery storage is not required. This has been made possible through seamless system integration provided by SolarGy Pte Ltd.

The electricity generated by the system serves as a supplement to electricity that is drawn from the grid of the building, hence reducing the consumption of fossil fuel energy.

With limited roof space and a sloping roof profile that is as steep as 19°, the project was challenging in terms of logistics planning and installation. As part of the architectural integration, odd corners of the solar arrays had to be filled up with dummy panels, so that the entire array blended smoothly with the curved profile of the roof. In this way, the solar panel installations are not only functional but aesthetic as well.

The solar system is capable of reducing approximately 45 tonnes of carbon dioxide emissions annually.

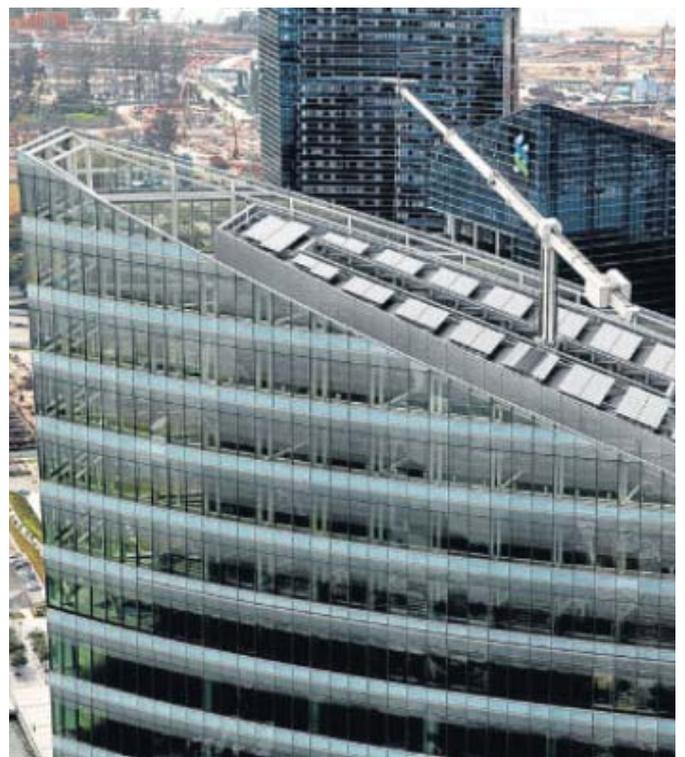

The roof of Ocean Financial Centre has a sloping profile.

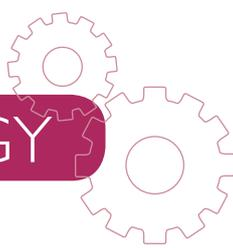

## Zero Energy Building

Located at BCA Academy, the Zero Energy Building (ZEB), said to be the first of its type in Southeast Asia, is an existing building that has been retrofitted.

As a critical test-bedding facility, the 4,500 m<sup>2</sup> ZEB aims to produce enough energy for its needs. Panasonic double (bifacial) solar panels powered with HIT technology, which can generate energy from both sides, with an output of 5 kWp, are installed on this building.

## Resorts World Sentosa

Singapore's largest photovoltaic system, utilising 2,397 Panasonic solar panels powered by HIT technology, with an output of 500 kWp, is installed on Universal Studios Singapore at Resorts World Sentosa, the republic's first integrated resort.

The system can generate more than 629,000 kWh of solar energy annually and thereby reduce carbon dioxide emissions by about 342 t a year.



Panasonic solar panels have been installed on Universal Studios Singapore.

## MALAYSIA

### Penaga Hotel

Hotel Penaga, located in the UNESCO World Heritage Site of Georgetown, Penang, Malaysia, is a 50-room hotel. It is the first heritage restoration project in Malaysia to receive the Green Mark Certification from Malaysia's Green Building Index.

The 20.79 kWp output installation at Penaga Hotel helps in the generation of clean energy, thereby facilitating a reduction in carbon dioxide emissions by up to 17,500 kg annually.

Much effort has been taken in this project to ensure seamless integration of the architecture and green technology.

With the help of Ditrolc Solar, a specialist in building integrated solar PV technology, Panasonic seamlessly integrated part of the PV system into the roof of the hotel itself. Part of the PV system was mounted on the original timber structure of the building while another part was retrofitted onto the back of the roof that is concealed from public view.

All images by Panasonic, unless otherwise stated.

## TEST-BED PROJECT FOR SINGAPORE PUBLIC HOUSING

In August 2011, Panasonic, in partnership with the Housing & Development Board (HDB), Energy Market Authority (EMA), and Economic Development Board (EDB), announced the commencement of a 'first of its kind' test-bed for total energy solutions in Singapore.

This project will see the company utilise and integrate its energy creation, storage, and saving solutions in an existing public residential building, in order to realise a greener lifestyle. The test will be conducted at the Punggol Eco Town which has been marked as one of the key 'living labs' for urban sustainability solutions in Singapore. It will run until 2013.

Panasonic will install its photovoltaic systems to supply renewable energy to power common facilities such as the lifts, water pump, and lighting, and will aim to achieve the zero emissions target. The company will also introduce its lithium-ion battery to store excess electricity generated by the solar panels during the day, for use at night, and to serve as a backup electricity generator.

It also plans to increase energy efficiency in the households by installing its Home Energy Management System (HEMS) in participating units in the block. This will help the households to monitor their electricity, water, and gas consumption patterns via an in-home display and better manage their energy consumption.

The Panasonic HEMS received the European Utility Award 2010 under the Customer Excellence category, recognising its pioneering initiative to spread customer-oriented, user-friendly, and fully-featured home energy management solutions to homes in Europe. Panasonic was the first Japanese company to win this recognition.

Panasonic will also explore collaborations with EMA in the Intelligent Energy System (IES) pilot. Through the use of smart meters and smart grid technology, the pilot seeks to test the feasibility of applications which could enhance the efficiency and resilience of Singapore's power system, and help consumers to better manage their energy consumption through the use of home energy management systems, time-of-use pricing, and incentives to encourage peak load shaving.





## The 'Green Mark Tool' - a new outlook towards Green Mark projects

With the Green Mark now established in Singapore, there is a clear and pressing need for an integrated solution that empowers industry to explore environment-friendly solutions effectively, determine whole building impacts, find design optimums, and do so rapidly in a commercial world of limited time-scales and consultant fees.

Dr Uma Maheswaran, Vice President, Jurong Consultants Pte Ltd, Singapore, and Mr Richard Quincey, Technical Director, Integrated Environmental Solutions, United Kingdom, introduce the key features of a new software solution, produced jointly by the two organisations, for the design of buildings.

The Green Mark, a dedicated green rating system for Singapore was launched in January 2005. Since its launch, the outlook for sustainable building projects has changed. The Green Mark has evolved rapidly and the recently launched version 4.0 for new buildings clearly demands a paradigm shift in the minds of consultants, especially for projects targeting higher levels of certification under this scheme. The energy requirements of the Green Mark, which had always been one of the highlight attributes, have been tightened further - this is in conjunction with an even more tightened baseline standard SS 553 - 2010.

Recently, Green Mark certification completed its 1000th project. This is a considerable achievement given the launch of the system in 2005. The rapid change and the high demand for the Green Mark system is driving the industry towards embracing what researchers in the field of sustainable built environment have always promoted - an integrated design process. This requires the multi-disciplinary team to consider all aspects of a building as a whole, work as a cohesive team, and quantify the impact of decisions on the overall performance of the building.

The construction industry is one of the most fragmented industries around. Often, design specialists work in silos with little thought to the wider impact of their design choices. Similar issues arise during construction and commissioning. This poorly integrated approach deprives the built environment of optimised solutions and thus the construction industry fails to meet its potential on delivering better more sustainable buildings. In defence of the construction industry, the Green Mark system requires greater design resource and time to carry out specialised studies, in order to produce optimised solutions

that deliver sustainable high performance designs that are, at the same time, commercially attractive.

### The importance of simulation tools in Green Mark projects

The aim of this article is to develop an insight into the structure The Green Mark rating system involves prescriptive credits and performance based credits, the intended result being a holistically balanced building design which ensures that energy, comfort, water etc are addressed proportionally.

Although most of the credits are prescriptive in nature, they require considerable resource and time intensive calculations to carry out. The stringent pre-requisites show a clear technical distinction between the Green Mark and other rating systems in the region.

The energy pre-requisites include a stringent Envelope Thermal Transmittance Value (ETTV) and an overall energy reduction for GoldPlus and Platinum projects. These target levels require a holistic approach, right from the concept design stage, in order to achieve the outcome in a commercially cost-effective manner.

The construction industry currently uses various simulation platforms for the overall energy modelling, none of which is tailored to Singapore's work practices or local standards, and a conventional manual spreadsheet system, with limited shade scenarios, for ETTV computations. All existing simulation platforms are also tailored to suit LEED (Leadership in Energy and Environmental Design) requirements established in the US, as LEED has been in existence for almost a decade now. However, the Green Mark uses its own benchmark and energy modelling approach. In particular, the standards and base case assumptions followed in Singapore are different to those for LEED. The following are the key distinctions between the assumptions in conventional energy modelling tools and Singapore requirements:

- Current energy modelling tools use either ASHRAE standards from the US or CIBSE UK standards for system design specifications and simulation method, whereas the Green Mark is based on Singapore local codes and standards. This creates a different baseline in terms of material specifications, lighting power budgets, equipment power densities, occupancy rates, schedules, and other vital information needed for energy modelling.
- Current tools have default system prototypes created for both heating and cooling systems and a lot of detailed attention is attributed to heating systems rather than cooling systems. This necessitates tailored approaches from consultants to manipulate system configurations to meet the 'cooling only' context of Singapore.
- ETTV is a key consideration in Singapore that needs to be modelled and integrated within the energy modelling context, as façade heat gain is a critical component of the cooling



loads in Singapore. Current energy modelling tools focus on individual material properties for base cases and not the whole base case design, as defined by ETTV and RTTV (Roof Thermal Transmittance Value).

There is no provision for the rapid determination / iteration of ETTV and RTTV for complex building / shading designs. This is a significant barrier to finding an optimum solution. Singapore's energy modelling framework includes mechanical ventilation fans for car parks and adopts an exceptional calculation approach to lifts, escalators, and pumps for inclusion into the energy modelling results. However, these are typically categorised under receptacles in current tools.

Similar issues also arise for non-energy assessments, notably with respect to daylight, comfort, and water. Thus, consultants in Singapore must adapt existing tools with a consequential impact on resource and time. Current simulation tools do not provide an ideal solution for meeting the needs and increasing overall energy savings, as demanded by the Green Mark.

## An introduction to the Green Mark Tool

Jurong Consultants' Green Mark Tool is said to be the first of its kind. It is a tailored, one-stop software solution that aims to support, comprehensively, professionals using the local Green Mark rating system.

The tool combines local expert knowledge with a globally accepted / accredited simulation tool (IES Virtual Environment) developed by Integrated Environmental Solutions, thus creating a localised simulation tool for demonstrating full compliance to Green Mark standards. The first version of the tool, targeted to be released in April 2012, aims to cover the complete energy credits under the Green Mark non-residential buildings criteria version 4.0. The key features of the Green Mark Tool are as follows:

- The Green Mark Tool utilises a Navigator approach. This interface delivers a user focused workflow approach that encodes real world experience of implementing the Green Mark. It ensures that even new users to this platform are guided through a step-by-step approach (Figure 1), to

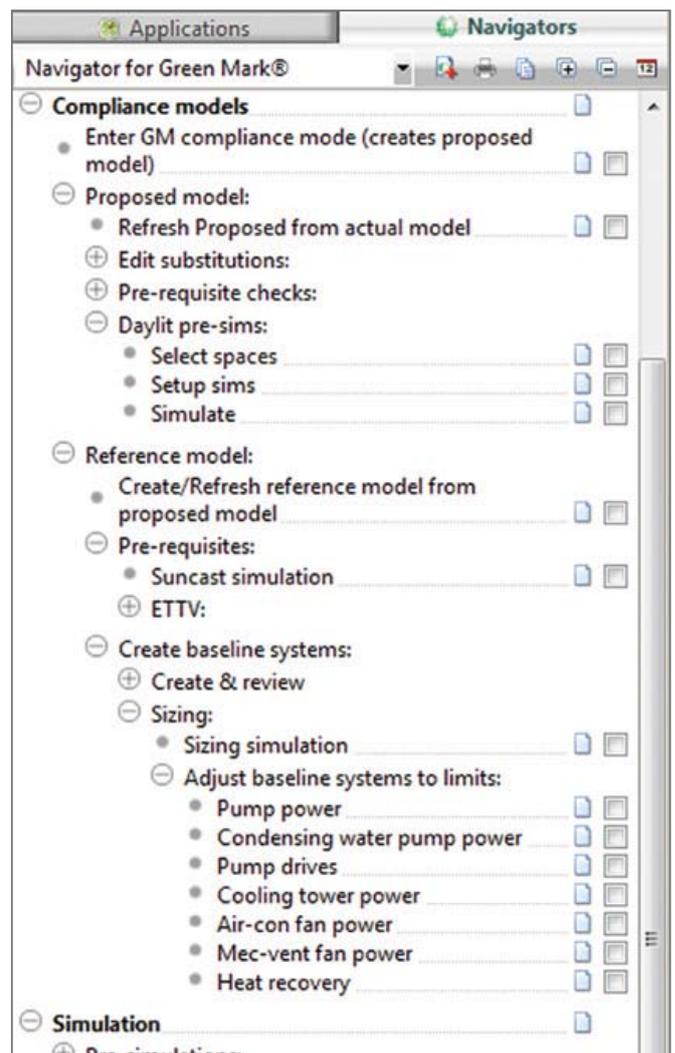
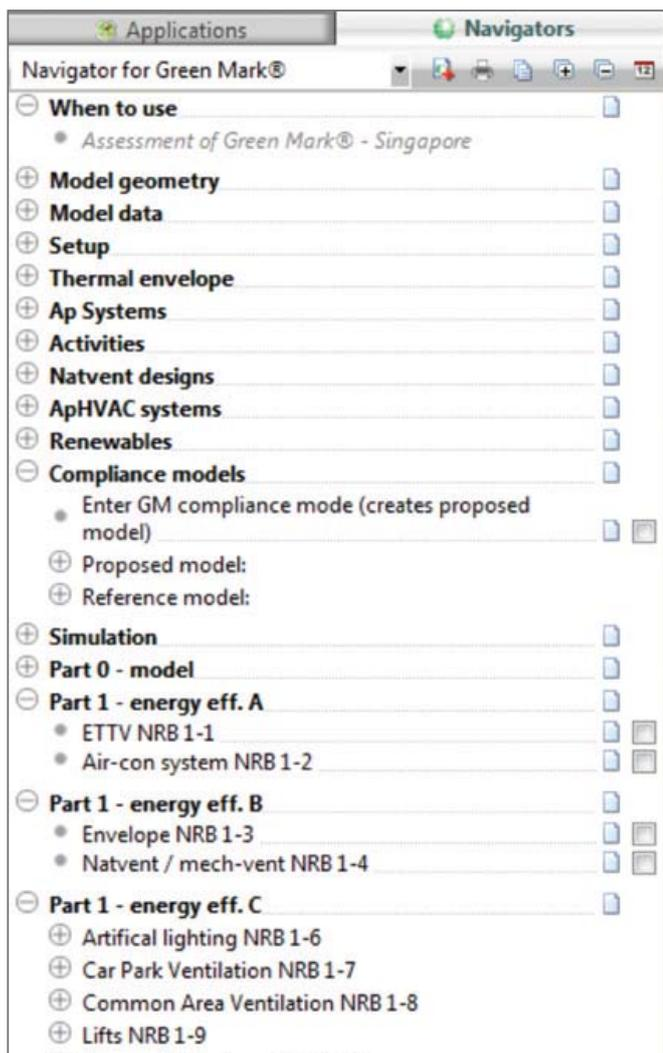

Figure 1: Screenshot of the step-by-step guided navigator system from the Green Mark Tool.

complete a complex model based on the local regulatory framework requirements and make Green Mark assessments. The Navigator automates many complex modelling processes, applies local standards, provides quality assurance, and generates rich output reports in the required format.

- A typical Green Mark energy modelling exercise involves a complex routine of steps (Figure 2) and two different scenarios are required to be simulated - a base case (which is created automatically by the software) and modelled in compliance with minimum local standards, and a proposed case which is modelled as close as possible to the actual design (the proposed case is created automatically from the actual design entered by the user).
- Generally, energy modelling platforms require users to key in information manually, space by space, through the information templates provided. However, Integrated Environmental Solutions can import a complete building model designed and developed in Sketch up and automatically compute the various design parameters, including space areas, volumes, façade areas, window to wall ratios, and others. Figure 3 shows the energy modelling approach through the Green Mark Tool, in which modelling the base case as well as building the geometry from scratch are completely eliminated.

- In addition to the above, a significant advantage is the reportage created by the Green MarkTool. The tool automates generation of credit by credit reports (Figure 4) for all energy credits in its first version and also automates submission forms like GMIS report for energy modeling submissions. Currently, completing the GMIS form is a significant task in its own right, as it involves listing the detailed input assumptions and presenting the output in a certain distilled format.

The Green Mark Tool utilises a versatile simulation platform, to obtain localised solutions for Singapore's green building industry needs.

A key intent of the tool is to ease the burden of learning / implementing the technical domain knowledge required for a comprehensive green building design, automate many complex / local standard requirements, greatly increase productivity (such that design iteration becomes a reality for the Green Mark and report creation is no longer cost prohibitive), and encourage all consultants to participate and understand their contribution in the development of a truly green building.

In conclusion, a simplified interface, a guided navigator approach encoding local knowledge, a significant degree of automation of the processes and local standards involved, plus automated reportage, can be deemed as good starting points for achieving the objective stated above.

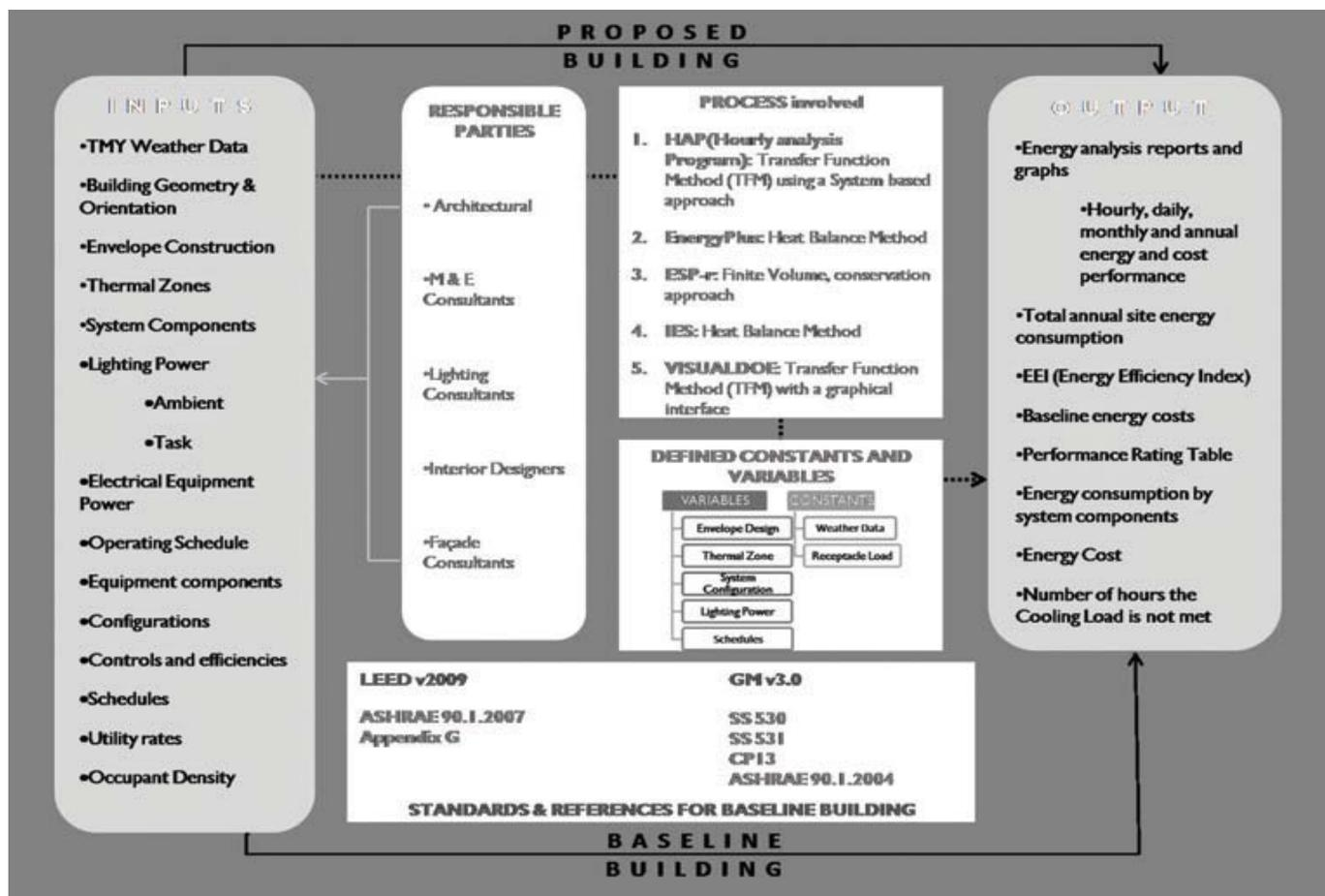

Figure 2: Typical energy modelling framework for Green Mark projects (Uma Maheswaran et al, 2009).

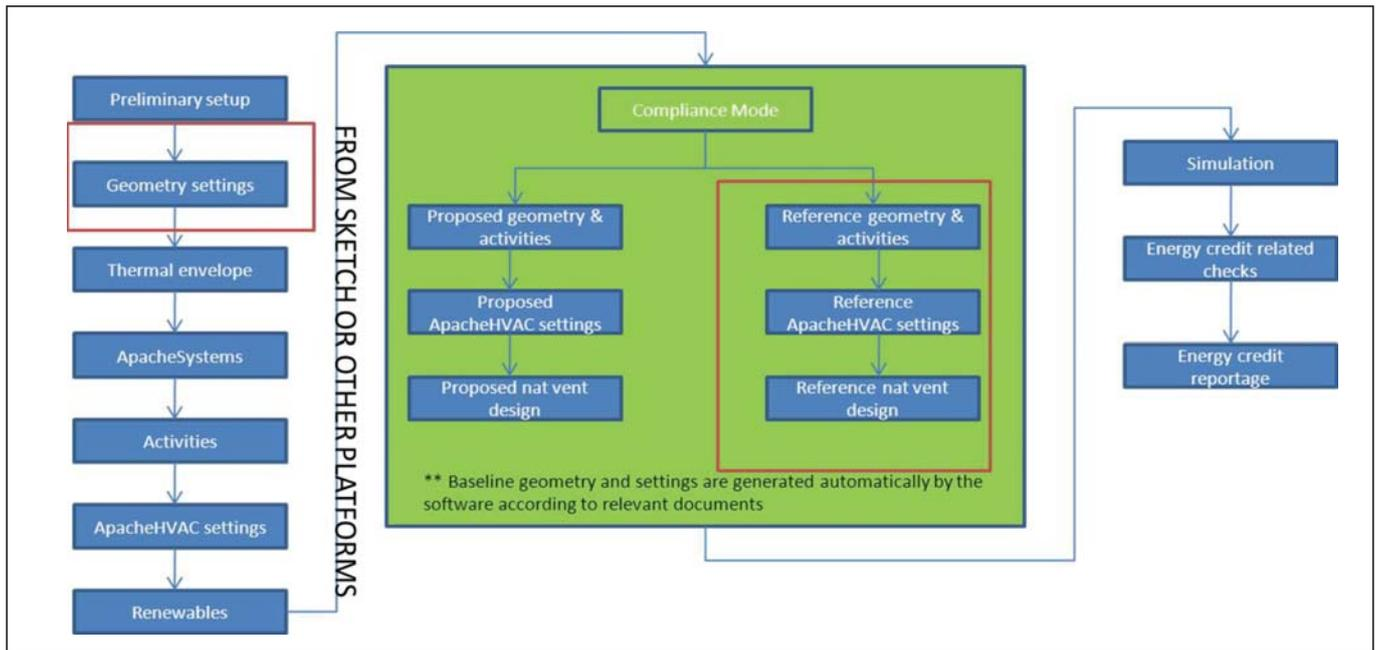
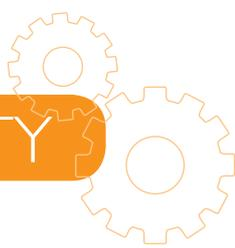

Figure 3: Energy modelling methodology through the Green Mark Tool.

**Thermal performance of building envelope NRB 1-1**

Green Mark New Buildings version 4  
 Air-con spaces floor area 28189m<sup>2</sup>  
 Nat-vent / mech vent spaces 0m<sup>2</sup>  
 No. of air-con spaces 98  
 Software: <Virtual Environment> version 6.5.0

**Result:**  
**Green Mark NRB 1-1** 12 points<sup>4</sup> (max 12)

**Analysis:**  
 ETTV<sup>5</sup> 36.6 W/m<sup>2</sup>  
 RTTV<sup>5</sup> 3.1 W/m<sup>2</sup>

Use the tables and charts to review the largest contributors to the ETTV; is it solar conduction that dominates? which spaces contribute the most? Focus design changes and capital cost expenditure on reducing the impact of the largest contributors first. Typically this will involve improving solar shading and/or glass solar performance. Shading from adjacent buildings and objects such as trees can also have a significant impact on designs however these are excluded from the ETTV analysis<sup>7</sup>.

**Notes:**  
 IES VE is an approved software tool<sup>8</sup>. Users are also required to submit the following information as documentary evidence:  
 - Architectural plans & elevational drawings  
 - Drawings of façade systems  
 - Specification & material schedules

**Calculation Summary:**  
 Location: London/Heathrow, United Kingdom  
 Weather file: KEV.FWT  
 Calculated: 09/February/2012 at 12:38  
 WWR: 26.0% Site Orientation: 0.0°  
 North: 25.0% North east: 0.0% East: 35.9% South east: 11.9% South: 42.2% South west: 17.0% West: 0.3% North west: 0.0%

Space	Floor	Gross area of external walls m <sup>2</sup>	Reference model ETTV W/m <sup>2</sup>	Proposed model ETTV W/m <sup>2</sup>
Sort A-Z	H/L	H/L	H/L	H/L
Apply		100	20	20
base	2	0.0	0.0	0.0
----	~	~	~	~

1. Use this summary to report to a certifiable solution
2. This analysis provides the ETTV, RTTV and Green Mark credits for valid air-con spaces in the project
3. ETTV and RTTV have been calculated in accordance with the BCA Code on envelope thermal performance for buildings
4. Projects with air-con & nat-vent / mech-vent spaces have credits NRB 1-1 to 1-4 area weighted. This is shown in the final points total for the credit
5. Where a project involves more than one building the ETTV and RTTV results are combined as if it is one building
6. An ETTV =< 50 W/m<sup>2</sup> is a prerequisite for all new buildings to reach certification
7. The VE automates solar shading assessments enabling complex geometry and shading devices. Adjacent buildings and trees are excluded from the analysis in accordance with the proscribed method.
8. IES VE meets the requirements of ANSI / ASHRAE Standard 140 and the Annex D requirements of Green Mark version 4. IES VE has been tested for the calculation of ETTV and approved by the BCA

Figure 4: Sample ETTV report that shows the formatted report in accordance with local submission requirements.

## References

BCA Green Mark website,  
[http://www.bca.gov.sg/GreenMark/green\\_mark\\_buildings.html](http://www.bca.gov.sg/GreenMark/green_mark_buildings.html)  
 'Singapore celebrates 1000th BCA Green Mark building project', The Straits Times, 29 February 2012.  
 Jurong Consultants Green Mark Tool website,  
[www.jurong.com/greenmarktool](http://www.jurong.com/greenmarktool)

GMS Application form,  
[http://www.bca.gov.sg/GreenMark/others/GMS\\_apply\\_public\\_v2.1.pdf](http://www.bca.gov.sg/GreenMark/others/GMS_apply_public_v2.1.pdf)  
 Uma Maheswaran, Sekhar SC, Haripriya Satyanarayanan:  
 'Energy modelling as a key performance evaluation technique in international green building rating systems', 10th Asia Pacific Conference on the Built Environment, Green Energy for Environment, Kaohsiung, Taiwan, November 2009.



## Lighting control systems for Hong Kong residential development



*Designed by Norman Foster, the Lily occupies a prime site on Repulse Bay Beach in Hong Kong.*

Lutron Electronics, a leading international lighting control systems specialist, recently announced that its GRAFIK Integrale and HomeWorks lighting control systems have been installed in all the serviced apartments and show flats in the Lily, one of Hong Kong's most striking and expensive residential developments. The sophisticated lighting control systems are designed to counter strong daylight glare and eliminate distracting internal reflections at night, thereby providing the residents with an unimpeded 180° panoramic sea view.

Occupying a prime site on Repulse Bay Beach, the Norman Foster-designed Lily comprises four interlinked residential towers which gently curve towards the famous beach and out across the South China Sea. It features an expansive curtain wall that enhances the view - the signature hallmark of the development which was inspired by the Calla Lily flower.

The specific lighting challenges brought by the curtain wall and dynamic positioning of the building meant that an intelligent lighting control system was needed to manage all aspects of the lighting set-up and enhance the internal ambience.

The interior design emphasises the softness and fluidity of its curved structure and its presence in the environment. Lighting ambience plays a critical role in this and hence lighting control systems from Lutron Electronics were considered and eventually specified.

In the serviced apartments, where tenants tend to come and go fairly frequently, a simple and user-friendly lighting system that is easy to operate was required. Lutron's GRAFIK Integrale enables users to control electric light effortlessly, even for the first-time. Instead of tapping individual switches like in a standard apartment, users can turn on individual or groups of lights through a central control unit. The system also helps occupants create different ambiances for different activities, at the touch of a button.

By dimming the lights to a comfortable level, GRAFIK Integrale can tackle the problems of glare and internal reflection on windows commonly found in homes without lighting controls. GRAFIK Integrale can control not only traditional incandescent and halogen

lamps, but also compact fluorescent lamps without the need for any interfaces. Users can control the lights directly from the main control unit or they can add as many keypads as they want.

In the penthouse suites, which are the most exclusive units within the Lily, there is a glass top skylight that adds natural light, a view, and a sense of grandeur to the apartment. Considering the elegant lifestyles of the penthouse suite residents, another sophisticated Lutron system, HomeWorks, was deployed to meet their needs.

HomeWorks provides integrated control of a home's lighting environment, regardless of home size. All lights and motorised window shades in the system can be controlled individually or operated together at the touch of designated buttons on Lutron keypads and remote controls, or an icon on the Apple iPhone, iPad and iPod Touch, according to preset scenes for different activities such as party, movie, or dinner. The HomeWorks system can be also integrated with other systems including audio or video systems, as well as fire and security systems, to provide additional convenience and safety.

Lutron's lighting control systems support the interior design in a three dimensional way, giving depth and layering effects to the decorative wall furnishings and loose furniture fittings, making them more vivid in the space and visually appealing to the occupant.

Lutron lighting control systems enable lights to be dimmed. Without sacrificing aesthetics and comfort for the residents, dimming allows the Lily to reduce energy consumption.

*Enquiry no: 03/101*



*Lutron's lighting control systems eliminate distracting internal reflections at night, thereby providing a panoramic sea view.*



*The lighting control systems support the interior design in a three-dimensional way.*



## The Hive



*The Hive, Schneider Electric's new global headquarters in Paris became the world's first building to earn the new ISO 50001 certification for energy management systems. It is also France's first building to obtain ISO 14001 and NF EN 16001 certifications.*

Schneider Electric's Hall de l'Innovation et Vitrine de l'Energie, better known as The Hive, is the company's new global headquarters in Paris. Opened in November 2008, the building accommodates approximately 1,800 employees over a 35,000 m<sup>2</sup> area.

Demonstrating Schneider Electric's commitment to energy efficiency, The Hive optimises its energy consumption while ensuring user comfort throughout the building. Mr Jeffrey Yap, Vice President, Singapore, Schneider Electric Buildings Business Unit, explains further:

The Hive is a comprehensive showcase of Schneider Electric's offerings. Originally a relatively ordinary building, it has benefitted over time from regular injections of Schneider Electric's energy management solutions. As a result, The Hive became the world's first building to earn the new ISO 50001 certification for energy management systems. It is also France's first building to obtain ISO 14001 and NF EN 16001 certifications.

The Hive recorded an annual energy consumption of 110 kWh/m<sup>2</sup> in 2009. The sharp reduction in energy consumption was made possible through data-driven analysis, recorded from the sub-metering installed throughout the building. More than 150 sub-meters have been installed at the origin, all connected to the advanced building management system.

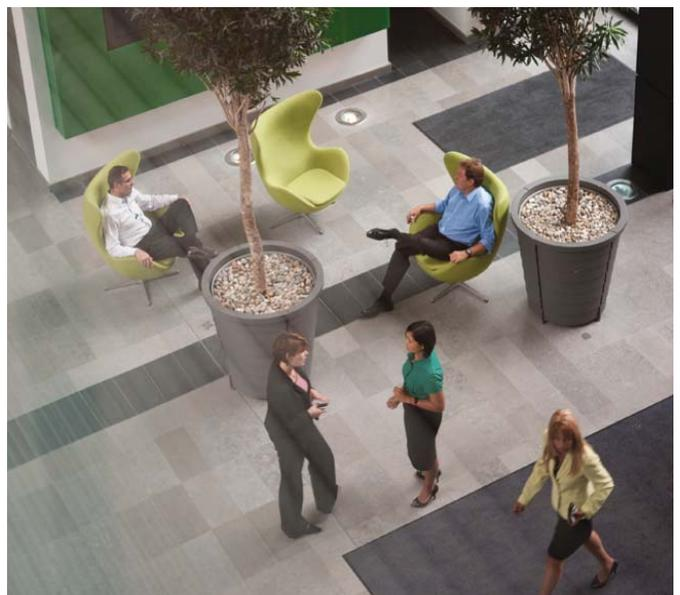

*The Hive optimises energy consumption whilst ensuring comfort.*



The Hive's energy consumption has been drastically reduced by roughly 60%, compared to the annual energy consumption of 320 to 350 kWh/m<sup>2</sup>, for Schneider Electric's previous headquarters (set across seven buildings). The company is aiming to further bring this number down to 80 kWh by implementing its active energy efficiency methodology. Additionally, The Hive's advanced automation system has allowed Schneider Electric to reduce maintenance costs by 30%.

For optimal management of The Hive, Schneider Electric has successfully managed to integrate all the building systems so they can communicate with one another. All systems share the same architecture, called EcoStruxure, and are all managed by a shared Building Management System (BMS). The Hive is equipped with Schneider Electric's BMS Continuum which enables native integration of all systems - HVAC control-signal, video surveillance, access control, intruder detection, electricity and heat meters, etc - through a shared internet protocol network.

The Continuum system also allows interoperability between office fittings, such as blinds, lighting, and air conditioning. This allows individual employees to regulate their environments using simple wall-mounted or wireless controls to adjust lighting, temperature, and sunlight, and create a comfortable space to work in. All these features are enabled by the BMS's ability to communicate via open, recognised protocols such as BACNET and LON.

Aside from comfort, Schneider Electric has also worked to guarantee the personal safety of employees working at The Hive, by equipping the building with a system of 45 Pelco cameras featuring night vision capability. The video surveillance can be used to display, record and, if need be, images can be sent from these cameras. The entire system of cameras functions on a TCP/IP architecture network and can be used to monitor data flow from any connection point on the network.

As it is impossible to manage what cannot be measured, one of the most critical systems in The Hive is the monitoring system that allows Schneider Electric to track energy consumption on a real-time basis. The entire building is equipped with electricity

and heat meters located as close as possible to energy-consuming equipment. Every 10 minutes, consumption readings are transferred to an energy monitoring portal, Vizelia, which generates performance reports and identifies any malfunctions. The software can also automatically process and take action on requests sent in by occupants of The Hive via a web portal (which can be accessed via PC, tablet, or smartphone).

Vizelia also plays a critical role in raising awareness and creating a better understanding amongst employees of the The Hive, on how they can contribute to reduce the environmental impact of their work. The software is able to show energy consumption data for each floor and department so that employees are able to quantify how their efforts have paid off in terms of energy efficiency. Schneider Electric believes that involving stakeholders - in this case the staff - is vital for improved management of the building's resources. Other initiatives, such as electing energy efficiency champions, are also being undertaken by Schneider Electric to improve residents' understanding of the long- and short- term advantages of improved energy efficiency.

The Hive also employs an Energy Manager who coordinates the efforts of different teams throughout the building, aimed at improving The Hive's energy and environmental performance. The Energy Manager oversees the building with a view to reducing energy consumption and carbon emissions, and is also responsible for maintaining the building's certifications, such as the ISO 50001 and ISO 14001.

Today's buildings are housing an increasing number of systems, all built on differing architectures and communications protocols. As far as Schneider Electric is concerned, the best way to optimise the management of a building is to have all these systems speaking as one. A building management system allows for convergence, so that systems which have been independently designed are able to communicate with one another and their interactions can be managed as a single unit.

*Enquiry no: 03/102*



*Schneider Electric believes that the best way to optimise the management of a building is to have all building systems communicating with one another.*



*Since electric vehicles will be included in the integrated management of every building in the future, Schneider Electric has already started providing parking spaces at The Hive, equipped with charging stations for electric vehicles.*

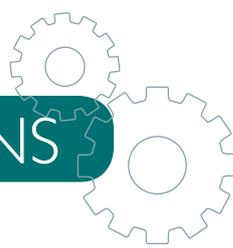

## Fluke offers 430 Series II three-phase power quality and energy analysers

Fluke Corporation, a global leader in portable electronic test and measurement technology, has introduced the Fluke 430 Series II three-phase power quality analysers - the first tools to use a patented algorithm to measure energy waste and quantify its cost. The 430 Series II helps facilities reduce electrical power consumption and improve the performance and lifespan of electro-mechanical equipment by providing the ROI justification to mitigate power quality distortion.

Previously, only experts could calculate how much energy was being wasted due to power quality issues. Utilities could calculate the cost but the required measurement process was beyond the reach of most electricians. With the new, patented Unified Power function of the 430 Series II, electricians, utility technicians, electrical engineers, field service technicians, and energy consultants can automatically determine how much power is being wasted, and calculate exactly what the extra consumption costs are, using a single hand-held tool.

In particular, the 430 Series II power quality analysers allow facilities to assess the impact of new energy-efficient, electronically-driven systems from lighting to motor controls, to HVAC. While these new models consume less energy as individual installations, they increase the level of power quality disturbance in the overall electrical system, increasing waste energy due to harmonics and reducing the total potential energy savings. The Fluke 430 Series II calculates the monetary cost of that waste energy.

Whilst the company's three-phase power quality analysers are already popular because of their simultaneous display-and-record capabilities, the updated 430 Series II models feature three new measurement functions as well as hardware, software, and firmware improvements. New models have up to 32 GB (8 GB standard) memory, a swappable SD memory card, and USB connectivity for longer power and energy logging and faster data download. Screen quality and battery life are both improved and the accompanying software has been redesigned to give users more options to analyse both power quality and power consumption. The two models are fully compliant with the stringent international IEC 61000-4-30 Class-A Standard. Each one can monitor systems with up to 10 power quality parameters on one screen and can record up to 150 parameters on four phases simultaneously, in accordance with the EN50160 Standard, and is safety rated 600V CAT IV/1000V CAT III.

The patented Unified Power function on the 430 Series II was developed through cooperation between Fluke Corporation engineers and University of Valencia scientists. Unified Power marks the first time that any test tool has provided the ability to automatically quantify the energy wasted by harmonics and unbalance, and by inputting the utility rate structure, the user can even calculate the monetary cost of the wasted energy.

The 430 Series II Inverter Efficiency function simultaneously measures the input and output power of inverters in solar

systems, wind turbines and uninterrupted power supplies, allowing the operator to see how much electricity the inverter itself is consuming and whether it is operating efficiently. The measurements enable operators to adjust settings or make a case for a replacement unit.



*The Fluke 430 Series II three-phase power quality analysers use a patented algorithm to measure energy waste and quantify its cost.*

The 435 Series II model includes PowerWave, a 'fast capture' system that displays waveforms and half cycle RMS voltage and current values in full detail, so motor and generator operators can measure the interaction during switching operations. This allows facility and utility service electricians, electrical contractors, and generator suppliers to easily gather measurements with one tool for load profiling, to prevent motor/drive/load mismatches, and for motor and generator commissioning and start-up testing.

The 430 Series II models include a soft carrying case, Li-ion battery pack with up to 10 hours of operating time per charge, current probes, test leads with clips, battery charger, USB cable, colour localisation set and PowerLog software.

Enquiry no: 03/103

## New release from Aspen Technology

Aspen Technology Inc, a leading provider of software and services to the process industries, recently announced a new release of Aspen PIMS and Aspen Petroleum Scheduler, that improves collaboration between refining planners and schedulers. Refiners can increase their profitability by optimising the accuracy and productivity of planners and schedulers. In addition, enhanced analytics provide planners and schedulers with better decision support, to rapidly respond to changing market conditions, or upsets in their operations.

The new release enables the sharing of operating targets between planning and scheduling functions, for closer alignment of plan and actual. This enables sharing of critical data such as production targets, model assays, and blend models, to enhance profitability and reduce margin loss.

Other key enhancements in the new release include new powerful analytics such as Spider Charts and Microsoft-based Excel PowerPivots, that help refiners visualise alternative feedstock selections. By quickly comparing many simultaneous scenarios, and easily sharing information across the organisation, refiners are in a better position to pick the optimal crude slate.

Enquiry no: 03/104



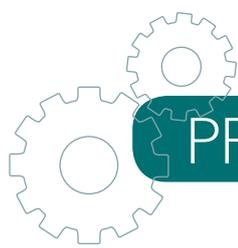

## DC-based electrical solutions for marine vessels



*The Onboard DC Grid is designed for ships with low-voltage onboard circuits.*

Launched in May 2011, the Onboard DC Grid, from ABB, which is part of a revival of power solutions using direct current (DC), will provide efficient power distribution and electric propulsion for a wide range of marine vessels.

In traditional electrical propulsion vessels, multiple DC connections are made to thrusters and propulsion drives from an alternating current (AC) circuit, accounting for more than 80% of electrical power consumption. ABB's Onboard DC Grid represents a step forward in optimised propulsion, by distributing power through a single DC circuit, thereby providing significant power savings.

The Onboard DC Grid is designed for ships with low-voltage onboard circuits, such as offshore support vessels, tug boats, ferries and yachts, and it can help to reduce fuel consumption and emissions by up to 20%.

With this solution, the vessel will be ready to maximise opportunities in energy savings with supplementary DC energy sources, such as solar panels, fuel cells, or batteries connected directly to the ship's Onboard DC Grid.

A key advantage of ABB's Onboard DC Grid is that the ship's engines no longer have to run at a fixed speed, so the engine's speed can be adjusted to optimise fuel consumption. By eliminating the need for bulky transformers and switchboards, the footprint and weight of the electrical system can be reduced by up to 30%, leaving more space on the vessels for passengers or cargo, while also providing greater flexibility in the positioning of system components in the vessel.

ABB recently won an order from ship owner Myklebusthaug Management to supply an Onboard DC Grid for a ship. The equipment will allow a new offshore platform support vessel,

under construction in Norway, to operate at the highest energy efficiency level to minimise emissions.

ABB will provide its full onboard DC system, including all power, propulsion and automation systems for the 93 m long, 5,000 t multi-purpose oil field supply and construction vessel which is scheduled for delivery in the first quarter of 2013.

*Enquiry no: 03/105*

## The Dyson Airblade hand dryer

The Dyson Airblade hand dryer is said to dry hands completely in 12 seconds. Powered by the Dyson digital motor, it is up to 80% more efficient than other hand dryers and is the only hand dryer to use a HEPA filter and be certified hygienic by NSF International, according to Dyson. The hand dryer is now available in 34 countries, with sales growing nearly 70%, from 2009 to 2010.

A leading Massachusetts-based research university study has shown that the Dyson Airblade hand dryer is the most sustainable way to completely dry hands. Paper towels and warm air hand dryers have the highest environmental toll, generating 70% or more carbon emissions than the Dyson Airblade hand dryer, according to this comprehensive lifecycle analysis (LCA). Rather than warm air, the Dyson Airblade hand dryer uses sheets of cool, clean air to literally scrape water from hands.

Dyson commissioned the research that looked at the entire life cycle of a product from cradle to grave. It took into account materials, manufacture, use, and end of life, as well as transport, dispensers, waste bins, and bin liners.

The peer-reviewed research was done in accordance with ISO Standards 14040 and 14044, and relied upon all available data from current and relevant LCA research conducted by manufacturers of paper towels, hand dryers and roller towels, to ensure impartiality and accuracy.

*Enquiry no: 03/106*



*The Dyson Airblade hand dryer.*

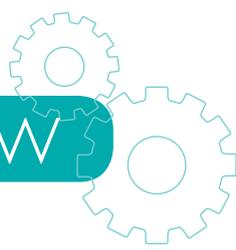

## Training students to become innovative engineers

'The Singapore Engineer' speaks to Mr Tom Joseph, Head of Worldwide Education for Autodesk, and finds out why the company places great emphasis on providing early opportunities for the development and application of software skills.



Mr Tom Joseph.

Autodesk Inc is a leader in 3D design, engineering and entertainment software. Customers across the manufacturing, architecture, building, construction, and media and entertainment, use Autodesk software to design, visualise and simulate their ideas. Since its introduction of AutoCAD software in 1982, Autodesk continues to develop a broad portfolio of software for global markets.

**Question:** Could you give a brief account of the development of AutoCAD, the company's flagship product?

**Answer:** This year we are celebrating AutoCAD's 30<sup>th</sup> anniversary. I realised very early in my career with Autodesk that AutoCAD was a well-known brand.

AutoCAD started off as one of several 2D CAD packages available at that point in time - all of them were priced differentially and they had different 'go to market' strategies.

One of the things that Autodesk very consciously did at that time was making AutoCAD readily available to everybody. We realised that rather than try to lock down the software and put in a lot of security and controls around it, we wanted everybody to use it more efficiently.

When we look back today, the decision to make AutoCAD widely accessible was one of the biggest factors for the product's success. As more and more people started using the product, they developed skill sets around it and AutoCAD eventually evolved into a standard for CAD. It became a standard for CAD when a majority of the CAD user base started using the product and wanted to exchange information in a consistent manner.

**Q:** Could you elaborate on Autodesk's interest in the field of education?

**A:** Today, the success of Autodesk depends on the number of engineers, designers, and artists, who graduate from educational institutions across the globe. They become our professional customers. Hence our interest in education.

In the area of education, we would like to do two things. Firstly, we would like to have more and more young children select these professions, going forward. We believe that if there are innovative and very talented engineers coming into the market, they can help in building the economies in their respective countries as well as create and invent new technologies which will help mankind. Secondly, we believe that we can harness innovation by giving them more exposure to software technologies at a very early age. When

you look at the lifecycle of usage of a software product, a certain amount of time is spent for a person to become familiar with the user interface, and it is only after the person becomes extremely familiar and therefore comfortable with operating the product, that the person can move from normal day-to-day work to innovative thinking. So if we can take that 'familiarisation' time-frame and move it into the educational institutions, when these students come out into the commercial space, they are automatically at a stage when they can be innovative with these tools.

That is the service we are planning to give out to society. With this objective in mind, we started our educational initiatives. Our focus is to provide technology, tools, and learning content to the entire educational segment.

**Q:** How do software tools assist in engineering education?

**A:** Post-secondary institutions teach engineering disciplines. Engineering requires the ability to conceptualise and visualise clearly in three dimensions.

What happens in a typical engineering institution is that a theory is taught and the lecturer is making an attempt to illustrate a theory in 3D, whereas the only medium he has available is in 2D. So the lecturer has to think in 3D, convert to 2D, and communicate to the student in 2D. The student then converts it to 3D in order to understand the concept.

The kinds of tools that we offer are adept at providing a continuous communication medium in 3D. The lecturer can visualise in 3D and illustrate in 3D, and the student can understand in 3D. The process of learning is significantly compressed because visualisation does not become a huge challenge for the student.

The way we position our tools in the post-secondary segment of the market is by taking these tools and embedding them into the curriculum, so that these become elements of the teaching process itself.

If you can illustrate in 3D, the student can learn very fast. So a lecture segment that normally takes 60 minutes can very effectively convey the same message and learning in half the time, if it is done using modern tools.

In order to move beyond concepts, students need to try different permutations and combinations of a concept. It can be done if he has the same tools as the lecturer. He can take the file on to his computer and start to tweak the values and observe the changes that take place. That is the best way of understanding the theory.

**Q:** Could you highlight some of the key features of your collaboration with the College of Engineering at National University of Singapore?

**A:** One of the main reasons for our involvement with the National University of Singapore (NUS) is its interest in developing engineering education using a different pedagogy, such as project-based learning.

For project-based learning, interdisciplinary solutions are extremely important. The benefit is that the engineering students



get to learn elements of different disciplines and thereby obtain a well-rounded education.

Autodesk, which we claim is the only company in the world today that has design solutions which are interdisciplinary, is able to facilitate project-based learning.

The intention is that along with NUS and Autodesk, if we have industry partners, they can give the students a project that takes, for example, several years to design and build. The students can go through their entire engineering curriculum with this project alone. It has elements of everything that an engineer needs to know, but the learning will be in the context of a particular example.

It is the intention of NUS to start a new course along these lines.

The Olin College, in the US, has been experimenting with this kind of pedagogy. We have been partners to Olin College for a couple of years. This synergy has also helped in the discussions with NUS.

Once we agreed, in principle, to support the programme, we went ahead and provided NUS with software and developed special curriculum.

We are looking at how we can bring commercial customers as industry partners into this venture so that we can have a change in pedagogy.

**Q: What are some of the company's other activities in the educational sector?**

A: Apart from the high-end activity mentioned above, at the secondary segment and regular post-secondary segment, we provide products to students, free of cost.

Today, every student across the globe, with no exceptions, can go on to our student portal, register themselves, and get all the software that professionals use, free of cost, for their personal use.

Using these products, students can learn engineering concepts, architectural concepts, and media concepts, in a faster learning cycle, and can also then become more adept and innovative in using these software.

We also work closely with governments, as well as with educational institutions and regulatory bodies, to conduct faculty development. It is one thing to provide software to students. We also need to make sure that faculty members are in a position to take the new tools and use them appropriately in the teaching process. We conduct development programmes for faculty members to upgrade their skills.

In addition, we engage with certain top-tier universities in the area of research, especially under the PhD programmes. We sponsor, and support technically, some of the applied research programmes relevant to Autodesk. In certain cases, we also support fundamental research.

**Q: What are the intended results from your current efforts?**

A: With all the activities happening, we believe we can build an environment wherein more and more students will prefer to go into the engineering disciplines.

We would like to compress the learning cycles and move some of the learning cycles that currently exist in the industry when the

student starts working, back to the educational institution. So we help develop more well-rounded students who are more job-ready upon graduation.

Overall, we believe that by doing these two things, innovation in the engineering space will improve, which will lead to better technology, better products, and a better environment for all of us to live in.

**Q: What do you see as some of the future developments?**

A: When I look forward, I can see a couple of trends that are going to change the way we go to market with some of our offerings.

The first is the proliferation of digital devices among students. Today, in any typical university campus, each student has at least two digital devices, on average.

So, when we look at their preferences today, they prefer those devices to be their window of communication with the outside world. They want all information to be streamed through these devices which are always switched on, and the students are very good at operating them. If this is the preference they have, from a learning perspective, what Autodesk would like to do, is to look at how we can take professional tools that work on large, resource-intensive computers, and provide them with a window / an interface wherein students can interact with these software but with a very much simplified user interface.

The other trend I notice in the education space is segmentation. We segment students today, based on their age, into primary, secondary, post-secondary, and university students.

But we have noticed in our engagements with educational institutions that, while this is a nice way of broadly classifying the student population, there are today more exceptions than the rule. What we understand as more important is not so much the age, but the ability of the student.

For example, the youngest certified user of our 3ds Max software is Ze Kun Chen from China. He was first certified when he was nine. Ze Kun began learning 3ds Max to help his family's display framing business because he realised that with 3D visualisations they could more easily explain their designs. He obtained a free student licence of 3ds Max through the Autodesk China Education Community, took advantage of the learning materials from the community and participated in software training at an Autodesk Authorized Training Center.

He obtained certification exam marks that were much higher on average than the scores of professionals. He had the creative abilities and understood how the software works.

We find many such examples on the campuses today.

Since the need of the hour is innovation in the commercial space, it is important to identify talented students at an early age and nurture their talents.

In summary, there are two new initiatives that we are focusing on. One is to bring complex industrial solutions to simplified digital devices, and the other is to provide an avenue for identifying and picking up potential innovators at an early age and nurturing them so that they can harness their talents.

## Asia Future Energy Forum & Exhibition 2012 to be held in Singapore in October

Masdar, Abu Dhabi's multi-faceted renewable energy company, and Reed Exhibitions recently announced their plans to hold the 'Asia Future Energy Forum & Exhibition 2012' (AFEF 2012), from 22 to 24 October 2012, as part of the annual Singapore International Energy Week (SIEW) organised by the Energy Market Authority of Singapore.

AFEF 2012 will be held at Sands Expo and Convention Centre, Singapore. It will address the theme 'Powering Sustainable Innovation in Asia', and will discuss energy-related issues, challenges, and opportunities in Asia. AFEF 2012 will be the marketplace for the clean, alternative energy suppliers to meet buyers from Asia. It will also be an opportunity to showcase Masdar's multi-faceted approach towards the acceleration, development and deployment of renewable energy and clean technologies.

With its exemplary track record in hosting global platforms such as the World Future Energy Summit, Masdar will support and participate in AFEF 2012 to drive debate, promote knowledge-sharing and strengthen collaborations.

Speaking on the collaboration, Dr Sultan Ahmed Al Jaber, Chief Executive Officer of Masdar, said, "Asia has emerged as a major player in the renewable energy sector. This is also signified by the strong Asian presence at the ongoing World Future Energy Summit this year. Over the past three years, Masdar has been organising the European Future Energy Forum in Spain, UK, and Switzerland. Now, with the emergence of Asia as a key partner in the renewable energy and clean technology industry moving forward, it only made sense that we place a targeted focus on Asia in 2012. This move is a testament to Masdar's agility in meeting the fast changing market needs in addition to Abu Dhabi's capability of exporting knowledge and expertise in the strategic energy sector. The decision to hold the event in Singapore, one of the UAE's most valued partners in Asia, is a great source of pride".

"We are honoured with these partnerships and will always continue looking for opportunities across Asia, as part of the UAE's initiative to build bridges and find the energy solutions of tomorrow", added Dr Al Jaber.

Mr Chee Hong Tat, Chief Executive of the Energy Market Authority, said, "Asia's energy demand is expected to double over the next 20 years, and renewable energy

sources will play a bigger role in the overall energy mix of many Asian countries. The Energy Market Authority is very happy to have the Asian Future Energy Forum & Exhibition (AFEF) as one of the anchor events of the Singapore International Energy Week (SIEW). AFEF will complement the other SIEW events in shaping Asia's energy future".

According to the International Energy Outlook 2011 report, renewable energy use will rise from 10% in 2008 to 15% in 2035. Asia is expected to play a major role in achieving these targets.

Mr Frederic Theux, President of Reed Exhibitions Middle East, commented, "As one of the leading lights of clean and sustainable development in the Middle East, Masdar has played a significant role in transforming the World Future Energy Summit into one of the world's leading platforms dedicated to the global renewable energy community in less than five years. Having successfully secured attendance and commitments from world leaders driving innovation, trade and investment opportunities in the renewable energy universe, Reed Exhibitions believes we are well placed to develop AFEF into a similar platform alongside SIEW to support the growing demand from Asia. We are pleased to share our knowledge and experiences with our team in Singapore in partnership with the Energy Market Authority, to deliver a successful event".

Ms Michelle Lim, Managing Director of Reed Exhibitions in Singapore, remarked, "Asia's growing economies will continue to face increasing demands for energy. It is widely regarded that only relying on traditional fossil energy to fuel economic development is highly unsustainable. There is therefore a compelling need for an event like AFEF as a marketplace for alternative, clean energy solutions. By modelling after the successful WFES through close partnership with EMA, and its highly successful SIEW, AFEF aims not only to enable the trading and sourcing of renewable energy products and services, it will also serve as a platform for networking and knowledge-sharing for the Asian community".

Reed Exhibitions currently organises some 19 events in the energy and oil & gas sector, and another nine in the environment & urban planning sector. The new addition will further boost Reed Exhibitions' presence in Asia.

## Power event in India to be held in April 2012

Co-located events, POWER-GEN India & Central Asia 2012, Renewable Energy World India 2012 and HydroVision India 2012 will bring together more than 100 international speakers and 250 exhibitors from over 30 countries.

Supported by the Ministry of Power, Government of India, the event will be held from 19 to 21 April 2012 at Pragati Maidan Exhibition Centre, New Delhi, India, and will address the theme 'Switching on India's POWER Future'.

With continuing strong population and economic growth, India's need for electricity has never been greater. India's primary energy demand will more than double by 2030, growing an average 3.6% every year and by 2050, the International Energy Agency estimates, India will need to add between 600 GW to 1200 GW of additional new power generation capacity.

The technologies and fuel sources India chooses to adopt to add to its electricity generation capacity will be critical to the level of impact on global resource usage and environmental issues.

Key implementation challenges for India's electricity sector include new project management and execution, plant upgrade and modernisation, accelerating energy-efficient exploitation of the nation's abundant renewable energy resources, overcoming financial constraints and high system losses, and improving equipment supply and transmission and distribution (T&D) capacity.

In line with the demand for energy and the exceptional growth required in the power sector to meet the nation's desired targets, POWER-GEN India & Central Asia 2012 along with the co-located events Renewable Energy World India 2012 and HydroVision India 2012, seek to address important technical and logistical issues facing the Indian government's ambitious plans to modernise its power infrastructure.

The event will open with an Inauguration Ceremony featuring keynote addresses by Shri P Umashankar, Secretary, Ministry of Power, India, and Shri B K Chaturvedi, Member-Energy, Planning Commission, India.

Over the course of three days, the conference will feature presentations on 28 topics at over eight sessions, delivered by over 100 international speakers representing more than 15 countries.

Critical issues and exciting new developments will be key subjects for discussion. These include Plant Refurbishment & Modernisation, Financing Hydro Development, and Securing a Bioenergy Future. Other prime topics expected to attract great interest include Minimising Conventional Power's Emissions, India's Hydroelectric Future, and Integrating India's Renewables.

Eminent speakers include Dr Anchal Bhowmick, Senior General Manager, Laymeyer Int, India; Mr Yukio Nakagawa, Deputy GM,

Hitachi Ltd, Japan; Mr Guru Neupane, Chairman, Arun Valley Hydropower Development Company, India; and Mr. Anders Brendstrup, Senior Vice President, DP CleanTech, China.

Alongside the conferences, the combined exhibition will feature over 250 companies from around the globe, presenting and demonstrating a range of products and design solutions for achieving long-term and sustainable energy supplies.

Leading exhibitors include Alstom, Doosan Heavy Industries, Foster-Wheeler, Hitachi Ltd Power Systems, and Tognum Asia.

Last year, the three co-located events attracted over 7,000 attendees from 41 countries, with even more expected this year, especially from the growing renewable energy sector.

### The Singapore Engineer Products & Solutions Enquiry Form

#### Product Information

I wish to receive more information on the following products that were featured in this issue of 'The Singapore Engineer' magazine.

Please list the enquiry number(s) of the product(s) that you are interested in. (Information is provided free-of-charge to all readers)

\_\_\_\_\_

Full Name: (Dr/Mr/Mrs/Ms/Er) \_\_\_\_\_

Designation (Job title): \_\_\_\_\_

IES Membership no. (if applicable): \_\_\_\_\_

Name of Organisation: \_\_\_\_\_

Address: \_\_\_\_\_

\_\_\_\_\_

State/City: \_\_\_\_\_ Postal Code: \_\_\_\_\_

Country: \_\_\_\_\_

Tel: \_\_\_\_\_ Fax: \_\_\_\_\_

Email: \_\_\_\_\_

Activity of Organisation: \_\_\_\_\_

Please complete the enquiry form and fax to 6467 1108 or email [Jeremy@iesnet.org.sg](mailto:Jeremy@iesnet.org.sg).



## Company aims to be biggest on-site solar power producer in the UK

Thames Water, the largest water company in the UK is to install photovoltaic systems large enough to cover 15 football pitches at three key sites in London, which will help the company to generate green energy from sunlight.

When completed, the three sites will provide an annual output of more than 4,500 Megawatt hours (MWh) of electricity, which is enough to power 970 average-sized homes.

The large solar arrays will provide 0.5% of Thames Water's annual energy needs. The company has plans to install smaller photovoltaic (PV) systems at up to 100 of its other locations delivering another 0.5% cent of energy.

The solar arrays are being fitted in otherwise unusable places at three operational sites in the capital - on the roof of a desalination plant, on top of vast storm tanks built in the 1800s, and on redundant sand filters.

Thames Water has signed a 25-year contract, valued at £ 7 million, with specialist PV company Ennoviga Solar, to install more than 100 PV systems at sites across the UK and maintain the arrays.

Although the scheme will cut the company's £ 80 million energy bill by only £ 100,000 a year, Dr Piers Clark, Commercial Director at Thames Water, argues it was the right thing to do for its customers and the company.

"With the price of energy forecast to increase above inflation, the way we have structured this agreement will give us a cheaper, renewable source of power from a secure source over the long term", he said.

"We think this is the right thing to do for our 14 million customers and to help move Britain that little bit closer to becoming a low-carbon economy", Dr Clark added.

Ennoviga was able to commission and build a 450 kW array on the roof of the Beckton desalination plant in Newham, East London, and 150 kW arrays at the Crossness sewage works in Bexley, South London, and the Walton water treatment works in Sunbury, West London, ahead of government changes to the feed-in tariff (FIT) rates for solar PV systems.

The company is now working to expand the Crossness and Walton arrays to 1,700 kW and 2,500 kW, respectively, bringing the system's capacity up to 4.5 GWh, under an expansion rule detailed in government regulations covering the FIT rates.

Being able to access the higher tariffs has been crucial in ensuring the financial viability of the Thames Water scheme, according to Mr Stefano Gambro, Director at Ennoviga.

He said; "The feed-in tariff scheme was launched in April 2010 to provide a stable investment climate so private investors would build this new capacity, and at the same time make Britain's electricity cleaner".

"By working with us, Thames Water has led the industry in exploiting otherwise unusable space to generate clean electricity. When energy prices rise and carbon charging starts, the impact on Thames Water customers' bills will now be that little bit less", Mr Gambro added.

The solar PV project will run alongside Thames Water's considerable anaerobic digestion operations that produce 16% of its electricity. Thames Water processes and pumps 2.6 billion litres of water a day and 2.8 billion litres of sewage a day.

Source: London Press Service.



Thames Water has vast areas of solar panels to generate green power.  
Image by Thames Water.

## Singapore celebrates 1000<sup>th</sup> Green Mark building project



*Pasir Ris Sports and Recreation Centre (SRC) is the 1000<sup>th</sup> green building certified under the Green Mark Scheme. The building received a Gold<sup>Plus</sup> rating under the New Non-Residential Buildings category. The green features of the SRC are expected to result in energy savings of 711,440 kWh/yr and water savings of 27,948 m<sup>3</sup>/yr.*

Singapore reached a new milestone when the 1000<sup>th</sup> green building was certified under the Building and Construction Authority's (BCA) Green Mark Scheme which was introduced in 2005. The 1000<sup>th</sup> project is the Pasir Ris Sports and Recreation Centre (SRC) which achieved BCA's Green Mark Gold<sup>Plus</sup> rating - the second highest under the green building rating scheme.

To mark this special milestone, about 500 residents from Pasir Ris-Punggol Group Representation Constituency (GRC) participated in a 'Walk the Green Talk' event. Led by Deputy Prime Minister (DPM) Teo Chee Hean who was accompanied by other Members of Parliament from Pasir Ris-Punggol GRC and Punggol East SMC, the walk began at Pasir Ris Elias Community Club and ended with a memorable award ceremony at Pasir Ris SRC.

DPM Teo, together with Singapore Sports Council's (SSC) Chief Executive Officer (CEO) Mr Lim Teck Yin, received the Green Mark Award from Mr Quek See Tiat, Chairman of BCA and Dr John Keung, CEO of BCA.

Commenting on the achievement, DPM Teo Chee Hean said, "Pasir Ris residents and grassroots leaders were actively involved in shaping the design of the Pasir Ris Sports and Recreation Centre, and I am delighted that the centre is now the 1,000<sup>th</sup> Green Mark building project. This is a significant milestone in the building and construction industry's efforts to incorporate green design and practices in new and existing buildings in Singapore. This will also help to mitigate climate change as the building

sector contributes 16% of Singapore's total carbon emissions. Indeed, the BCA Green Mark scheme is an integral part of our national efforts to reduce emissions, contribute to global climate change mitigation efforts, and create a sustainable living environment for our future generations".

Pasir Ris SRC is a 'first of its kind' eco-friendly SRC designed with green features to complement the natural surroundings of the adjoining Pasir Ris Town Park. An interactive public display system located at the foyer of the SRC allows visitors to learn more about the centre's green initiatives, as well as keep track of the building's energy consumption. The building is fitted with energy- and water- efficient features such as LED lighting and incorporates passive design to enhance daylighting and natural ventilation in common areas. In addition, louvres have been installed on the building's façade, which act as sunshading screens to prevent heat gain into the building. These wooden louvres were recycled from timber seats at the old National Stadium and given a new lease of life.

As a Green Mark Gold<sup>Plus</sup> certified building, the SRC is 25% more energy-efficient than an average building without green features. The centre also boasts an impressive 170 kWp photovoltaic system on its rooftop, which is expected to generate about 207,380 kWh of electricity each year to support up to 12% of its annual energy consumption. This is equivalent to the amount of energy used to power up 45 four-room HDB flats and will help the centre save about S\$ 57,000 annually (based on an

estimated tariff rate of S\$ 0.276/kWh).

Another interesting feature is an exercise bicycle in the gym, which allows the user to generate electricity while shedding some pounds. The electricity generated from the bicycle can be stored to power up the television in the gym for more than eight hours.

“We are delighted to receive the Green Mark accolade as it recognises the deliberate effort that we have taken to create a user-friendly and eco-friendly Pasir Ris SRC. The ‘sports in a park’ concept with green designs and environmentally friendly features, as well as the seamless connection to the neighbouring park and water body, will not only increase the awareness of environmental sustainability among Singaporeans, but also create a conducive place for families to bond and enjoy sports”, said Mr Lim Teck Yin, CEO of SSC.

Dr Keung, CEO of BCA added, “We are glad that more and more building owners and developers are coming forward to ‘green’ their buildings, even beyond the minimum mandatory standards, as they are becoming more aware of the benefits of providing an eco-friendly environment for the occupants. Moving

forward, we also want to reach out to building occupants or the consumers, to encourage them to ‘walk the green talk’ and follow the government’s lead in creating the demand for more environmentally friendly buildings in the near future. In fact, our latest Green Mark schemes, which assess office interiors, schools and restaurants, are part of BCA’s plan to place more emphasis on users’ behaviour and cultivate them to play a greater role in Singapore’s green building movement”.

Since 2005, the number of Green Mark building projects in Singapore has increased exponentially from only 17 in the first year to 1,000 today. Singapore is well on target to ‘green’ at least 80% of all its buildings by 2030. At present, about 13% of the buildings in Singapore have achieved the BCA Green Mark standard, translating to a gross floor area of 29 million m<sup>2</sup>.

The BCA Green Mark scheme is supported by a host of incentives, including the S\$ 100 million Green Mark Incentive Scheme for Existing Buildings (GMIS-EB), the Green Mark Gross Floor Area (GM-GFA) Incentive Scheme, and the latest Building Retrofit Energy Efficiency Financing (BREEF) scheme.



*Energy-efficient fittings: Extensive use is made of energy-efficient LED lighting, which have a longer life span, in key areas such as the foyer, offices, meeting rooms, and corridors.*



*Water efficient fittings: The majority of the water efficient fittings were selected from the Water Efficiency Labelling Scheme (WELS).*



*Irrigation system: Rainwater is harnessed to irrigate the landscaping, thereby reducing the consumption of potable water.*



*Greenery: The extensive use of greenery reduces the heat island effect. At the same time, the greenery provides a seamless transition to the adjoining Pasir Ris Town Park.*





*Rain garden for storm water management: Rainwater run-off from the tennis courts and driveway is channelled into the rain garden. The rain garden acts as a natural filter prior to releasing the water into the public drainage network.*



*Ventilation in common areas: The building was designed to reduce reliance on air conditioning, by having most of the common areas naturally ventilated.*



*Sunshading: Materials reclaimed from the old National Stadium's timber seats have been recycled as louvres which provide sunshading on the external façade.*



*Photovoltaic system: Solar panels have been installed over an area of about 2,400 m<sup>2</sup>, on the roof, to tap the sun's energy.*



*Human generated energy: The gym equipment allows users to generate energy to power up the television.*

#### PROJECT CREDITS

##### Client / Developer

Singapore Sports Council

##### Project Manager

CPG Consultants Pte Ltd

##### Architect

CPG Consultants Pte Ltd

##### M&E Engineer

CPG Consultants Pte Ltd

##### Structural Engineer

CPG Consultants Pte Ltd

##### Quantity Surveyor

CPG Consultants Pte Ltd

##### Main Contractor

Quek Hock Seng Construction Pte Ltd

##### ESD Consultant

CPG Consultants Pte Ltd

##### Acoustics Consultant

CCW Pte Ltd

## LNG terminal will diversify energy sources

Singapore's first liquefied natural gas (LNG) terminal will enable geographical diversification of LNG imports, thus making the republic less susceptible to price and supply risks. When it comes on-stream in 2013, the terminal will allow Singapore to import gas from countries all over the world.

As a fuel source, LNG will play an important role in addressing challenges relating to energy security, economic competitiveness, and environmental sustainability.

### CONSTRUCTION UNDERWAY

Located on Jurong Island, the LNG terminal is about 80% complete. Since the terminal's groundbreaking in March 2010, construction of key installations, including the first two LNG storage tanks and the primary jetty, are well underway.

The LNG terminal will have a throughput capacity of 3.5 million tonnes per annum (Mtpa) when it is operational in the second quarter of 2013. This capacity will increase to 6 Mtpa by the end of 2013 when additional jetties and regasification facilities are completed. The terminal's third tank is targeted for completion by the first quarter of 2014. Each tank is 53 m high and can hold 180,000 m<sup>3</sup> of LNG.

### FUTURE LNG PROCUREMENT

The current LNG aggregator for Singapore, BG Singapore Gas Marketing has sold about 2.65 Mtpa of LNG and the quantity is expected to reach 3 Mtpa by 2013. As BG has an exclusive licence to import LNG and sell regasified LNG in Singapore for up to 3 Mtpa of LNG or until the year 2023, whichever is earlier, a study is underway to explore several possible frameworks for future importation of LNG, once BG's contract ends.

The Energy Market Authority will issue a post-3Mtpa LNG import consultation paper to gather industry and public feedback. Noting that the needs of consumers and the LNG terminal's efficiency are key considerations for the framework, it should allow Singapore to continue to access competitively-priced and reliable supplies of LNG.

When completed, the LNG terminal will contribute to the development of Singapore as a regional gas hub and is expected to create new job opportunities for Singaporeans in a significant and rapidly growing industry.

### FACTS & FIGURES

The LNG terminal will comprise three tanks and three jetties and will have a throughput capacity of up to 6 million tonnes per annum (Mtpa).

#### LNG tanks

Each of the three LNG tanks being constructed is 53 m high and 90 m wide. Each tank can hold 180,000 m<sup>3</sup> of LNG.

Totally, 27,832 m<sup>3</sup> of concrete, 5,032 t of steel reinforcement bars, and 3,681 t of steel plate are used for each tank.

Each tank sits on an area of 6,358 m<sup>2</sup>, with 562 steel piles driven for its foundation. Two additional layers of nickel steel plate and carbon steel plate line the inside of the 1 m thick concrete walls of each LNG tank.

The roof of tanks 1 and 2, each weighing 1,200 t, were first built at ground level and then raised to a height of 53 m, using compressed air. At a speed of about 200 mm/minute, the raising of each roof took around four hours.

#### Pipes

Totally, there are 1,555 tonnes of piping in the pipe racks at the LNG terminal.

#### Regasification capacity

The LNG terminal will have an initial regasification capacity of 3.5 Mtpa of LNG when operational in the second quarter 2013. This will increase to 6 Mtpa when the additional jetties and regasification facilities are completed by end of 2013. Regasification is the act of warming LNG from its liquid state to its gaseous state.

#### People

Currently, there about 1,400 people working on the LNG terminal construction site.



Artist's impression of the LNG Terminal with the primary, secondary, and tertiary jetties.

### ADVERTISERS' INDEX

INFINEON TECHNOLOGIES	INSIDE FRONT COVER
PENNWELL CORPORATION	PAGE 5
PHILIPS ELECTRONICS	PAGE 3
SINGAPORE INSTITUTE OF TECHNOLOGY	OUTSIDE BACK COVER

# The IES Journal Part A: Civil & Structural Engineering Vol. 5 is out now!

## Promotion: 10–15% Off!



Dear Members

Now indexed by SCOPUS and Compendex, the IES Journal is written by world renowned researchers and practitioners. The Journal provides a forum for the dissemination of original research and developments in civil & structural engineering.

The papers cover a wide range of engineering issues in structural, geotechnical, water resources, environmental and infrastructural fields, and offer a focused, vibrant and timely communication tool for researchers, consultants and industry practitioners.

From now till 29 June 2012, subscribe to the IES Journal Part A: Civil and Structural Engineering Vol. 5 and get 10% off for one year's subscription (S\$72) and 15% off for two years' subscription (S\$136). The usual price for a year's subscription is S\$80.

The 2012 volume of the IES Journal Part A is published on a quarterly basis. Visit the publisher's website at <http://www.tandf.co.uk/journals/tia> for more information as well as a sample copy.

The order form can be downloaded at <http://www.ies.org.sg/publication/journals/IESJOFFeb2012.pdf> and can be sent to [jeremy@iesnet.org.sg](mailto:jeremy@iesnet.org.sg)

Call 64695000 for any further queries!



Take your ambitions further with a specialised engineering degree from a world-renowned overseas university, in partnership with SIT.

**KNOW-HOW  
TO SUCCEED**

[www.SingaporeTech.edu.sg](http://www.SingaporeTech.edu.sg)  
[www.facebook.com/SingaporeTech](https://www.facebook.com/SingaporeTech)



**OVERSEAS UNIVERSITY PARTNERS**

NEWCASTLE UNIVERSITY | TECHNISCHE UNIVERSITÄT MÜNCHEN | UNIVERSITY OF GLASGOW | THE UNIVERSITY OF MANCHESTER |  
THE GLASGOW SCHOOL OF ART | DIGIPEN INSTITUTE OF TECHNOLOGY | WHELLOCK COLLEGE | THE CULINARY INSTITUTE OF AMERICA |  
UNIVERSITY OF NEVADA, LAS VEGAS

**POLYTECHNIC PARTNERS**

NANYANG POLYTECHNIC | Ngee ANN POLYTECHNIC | REPUBLIC POLYTECHNIC | SINGAPORE POLYTECHNIC | TEMASEK POLYTECHNIC

Singapore Institute  
of Technology

Established in 2009  
A Ministry of Education Initiative